

SECTION 26 05 00: Common Work Results for Electrical

Document revision history: 08/2019 – Original Publication

Date	Section	Description of Change

PART 1 – GENERAL**1.1 Summary**

- a. Summary of requirements for design documents.

1.2 Demolition

- a. All deleted items must be removed and not just abandoned; fixtures and devices shall be physically removed, conduits, pull boxes and outlet boxes shall remain.
- b. No demolition of one item shall occur in order to repair and/or replace another item.
- c. Splices are not allowed in feeders. Where conductors are not sufficiently long enough to reconnect to new equipment the existing conductors must be removed and new conductors installed.

1.3 General

- a. For remodel projects, regardless of size, where new electrical switchboard, distribution board or panelboard is provided a complete one-line diagram shall be provided. A demolition and new one-line diagram is required. One-line diagrams, in AutoCad, are available from the University for most buildings. Partial one-line diagrams are not allowed.

1.4 Space Requirements:

- a. Dedicated electrical rooms are required vs. in combination with data/telecom.
- b. Exterior placement of any and all equipment requires CPM and FS approval to ensure compliance with the UO Campus Plan. If approved, all University policies shall be followed.
- c. Spaces designed to accommodate partition/component office systems must provide adequate power in perimeter walls and/or floor-boxes. This will accommodate the use of components without built-in wiring.
- d. No electric equipment or pathways allowed in chlorinated air or water spaces.

1.5 Accessibility of Equipment

- a. Accessible is defined as being capable of being reached without climbing or crawling under or over obstacles such as motors, pumps, belt guards, transformers, piping and ductwork. Access must not exceed 14ft in height, a typical ladder working height.
- b. A drawing layer of 'Maintenance Access' is to be incorporated into ALL drawings and system designs. This layer MUST be maintained through all phases of design and construction.
- c. Refer to and abide by all OSHA requirements, as appropriate.
- d. OSHA 1910 Subpart D - Walking-Working Surfaces standards for working platforms must be followed. Provisions to meet these standards must be incorporated into the building design.
- e. Design and installation of all equipment shall be accessible for operation, maintenance, repair, and replacement as required by NEC and OSHA General Requirements. - 1910.303.
- f. All necessary access points for maintenance must be provided and coordinated.
- g. No equipment shall be accessed via restrooms.
- h. Equipment above ceilings shall be located within corridors or above doorways.
- i. Thorough coordination of ceiling access(s) with electrical equipment above.
- j. Cabinet, enclosure, panel doors, etc. shall open unobstructed 180°.

- k. Cabinet, enclosure, panel doors, etc. in main electrical rooms opposite and/or beside another shall open unobstructed and clear each other.
- l. In mechanical and electrical rooms any components requiring routine service/maintenance must be installed / mounted below 7ft in height. Prior to installation of any component above 7ft requires onsite review and explanation with FS Maintenance and/or FS Electrical Supervisor.

PART 2 – PRODUCTS

- a. Not applicable.

PART 3 – EXECUTION

- a. Not applicable.

SECTION 26 05 19: Low-Voltage Electrical Power Conductors and Cables

Document revision history: 08/2019 – Original Publication

Date	Section	Description of Change

PART 1 – GENERAL**1.1 Summary**

- a. Wire and Cables
- b. Connectors
- c. Splices
- d. Lugs and Pads

1.2 Submittals

- a. Product Data: Provide for cable, terminations and accessories.

1.3 Qualifications

- a. Not applicable.

PART 2 – PRODUCTS**2.1 Conductors and Cables:**

- a. Materials:
 - Wiring shall be copper and shall be rated at 600 volts.
 - i. Aluminum conductors are not allowed.
 - Wire sizes 14, 12, 10 and 8 shall be stranded only. NO solid copper material.
 - Molded connectors with metal thread-on core shall be used for splicing 14, 12 and 10 wire.
- b. Manufacturers known to be acceptable are as follows:
 - Wire and cable: Rome, General Cable, Southwire, Anaconda-Erickson, Okonite, General Electric, Excell.
 - Molded connectors: 3M; Buchanan.
 - Tape: 3M.
 - Wire pulling lubricant: Polywater; Aqua Gel (clear); NO Ideal 77 Yellow.
- c. MC cable is allowed only for connection from j-box to light fixture. See Execution for more information.
- d. AC cable is not allowed
- e. Wire & Cable Identification:
 - 208Y/120V System:
 - i. Phase A - Black
 - ii. Phase B - Red
 - iii. Phase C - Blue
 - iv. Neutral - White
 - v. Equipment Ground – Green
 - vi. Isolated Grounds:
 - ◇ Green w/ Yellow stripe #12 and #10
 - ◇ Green and Yellow bands #8 and up
 - vii. Travelers – Purple
 - viii. Switch Leg – Pink

- 480Y/277V System:
 - i. Phase A – Brown
 - ii. Phase B – Orange
 - iii. Phase C – Yellow
 - iv. Neutral – Grey or White with an identifying stripe
 - v. Equipment Ground – Green
 - vi. Travelers – Purple
 - vii. Switch Leg – Pink

PART 3 – EXECUTION

3.1 Installation

- a. Use only approved lubricants; oil or grease shall not be used to lubricate wires.
- b. Couplings and conduit connectors shall have pre-insulated bushings in place before pulling wires.
- c. Splices in feeders are not allowed.
- d. No shared neutrals. Provide a separate neutral for each phase conductor in branch circuits
- e. MC cable is allowed only for connection from a single junction box to a single light fixture. Daisy chaining from fixture to fixture with MC cable is not allowed.

3.2 Interface with other products

- a. Provide labeling per Section 26 05 33, Identification of Electrical Systems.

3.3 Testing

- a. Test and inspect per NETA Standard ATS section 7.3.2 and as outlined in the commissioning of electrical systems.

3.4 Training

- a. Not applicable.

SECTION 26 05 26: Grounding and Bonding for Electrical Systems

Document revision history: 08/2019 – Original Publication

Date	Section	Description of Change

PART 1 – GENERAL

1.1 Summary

- a. Work Included: Provision of materials, installation and testing of:
 - Grounding and bonding systems

1.2 Submittals

- a. Product Data: Provide for ground rods, cable, terminations and accessories.
- b. Test reports

1.3 Qualifications

- a. UL 467
- b. ANSI/NFPA 70

PART 2 – PRODUCTS

2.1 Conductors and Cables:

- a. Materials:
 - Wiring shall be copper.
- b. Manufacturers known to be acceptable are as follows:
 - Wire and cable: Rome, General Cable, Southwire, Anaconda-Erickson, Okonite, General Electric, Excell.

PART 3 – EXECUTION

3.1 Installation

- a. Ground Bus: Rectangular, pre-drilled and tapped copper bar, ¼" x 4" x 12"
 - Locate exposed in main electrical room
 - Terminate all grounding electrode bonding jumpers and grounding electrode conductor at this bar.
 - Grounding electrode conductor to be installed between the bus bar and main switchboard.
 - No stacked lugs
- b. No.6 or smaller grounding conductors shall have green insulation.
- c. No.6 and larger are to be identified at accessible points per NEC 250.19A1.A2.
- d. All connections/terminations are to be cad welded, crimped, or compression type. Connections may NOT be mechanically reversible.
- e. All pig-tails are to use stranded wire.
- f. No reduction in size of grounding conductor allowed.
- g. Grounding wire is to be pulled into ALL conduits.
- h. All switches and receptacles must have a neutral wire pulled.
- i. Grounding electrodes for every building:
 - Metal Underground Water Pipe
 - Metal in-ground support structures
 - Concrete-encased electrode
 - Ground rod

- j. Grounding electrode for buildings housing specialized electronic systems:
 - Ground ring
- k. Supply Side Bonding Jumper:
 - For Oil Filled, Medium Voltage, Transformers fed from the University's primary distribution system a supply side bonding jumper shall be provided from the switchboard to the transformer.
- l. Pad mounted transformer vault:
 - 4 ground rods, one at each corner. #2/o copper conductor ground ring around the vault and connection to grounding electrode system.
- m. Signal and Communications Requirements:
 - Provide per Division 27 and EIA/TIA requirements

3.2 Interface with other products

- a. Section 26 05 19 Low-Voltage Electrical Power Conductors

3.3 Testing

- a. Inspect and test per NETA standard ATS section 7.13

3.4 Training

- a. Not applicable.

SECTION 26 05 29: Hangers and Supports for Electrical Systems and Equipment

Document revision history: 08/2019 – Original Publication

Date	Section	Description of Change

PART 1 – GENERAL

1.1 Summary

- a. Work Included: Provision of materials, installation and testing of:
 - Bracing and support systems
 - Engineered support drawings as required per project.

1.2 Submittals

- a. Product Data: Provide for ground rods, cable, terminations and accessories.
- b. Engineered drawings

1.3 Qualifications

- a. SMACNA
- b. Structural Engineer Licensed in the state of Oregon

PART 2 – PRODUCTS

2.1 Conductors and Cables:

- a. Materials:
 - Conduit straps
 - Trapeze support
 - Wall Supports
 - Channels
- b. Manufacturers known to be acceptable are as follows:
 - Manufacturers known to be acceptable for one or two-hole push-on strap: Appleton; Raco; Thomas & Betts.
 - Manufacturers known to be acceptable for one or two-hole pipe strap manufacturers: Kindorf.
 - Manufacturers known to be acceptable for lay-in pipe adjustable hanger manufacturers: Kindorf; Steel City; Pline.
 - Manufacturers known to be acceptable for trapeze or wall surface supports: Kindorf “bolt-hole” base galvanized steel channels with C105 and C106 single bolt pipe straps.
- c. Prohibited Material
 - Prohibited Materials: nails; wires; perforated tape; no anchor drives of any kind; J-nails.
- d. Engineered Drawings:
 - Support system to be designed by a structural engineer licensed in the state of Oregon
 - Support systems to include, but not limited to, pipe supports, trapeze, equipment supports and seismic restraint.

PART 3 – EXECUTION**3.1 Installation**

- a. Seismic bracing must be provided for equipment and piping per SMACNA and NEC requirements.
- b. Install per engineered drawings where provided.
- c. J-hooks, trays, etc. are acceptable only if wire/cable is properly bundled and/or gathered.
- d. Galvanized steel channels and associated support rods shall be selected to accommodate weight of associated raceway and wire.

3.2 Interface with other products

- a. Not applicable.

3.3 Testing

- a. Not applicable.

3.4 Training

- a. Not applicable.

SECTION 26 05 33: Raceways

Document revision history: 08/2019 – Original Publication

Date	Section	Description of Change

PART 1 – GENERAL**1.1 Summary**

- a. Work included: Provision of materials and installation of:
 - Conduits

1.2 Submittals

- a. Product Data: For each raceway and box product indicated.

1.3 Qualifications

- a. Not applicable.

PART 2 – PRODUCTS**2.1 Conduits, Tubing and Fittings:**

- a. Galvanized Rigid Conduit (GRC)
- b. Intermediate Metallic Conduit (IMC)
- c. Electrical Metallic Conduit (EMT)
- d. Flexible Metallic Conduit (FMC)
- e. Liquid Flexible Metallic Conduit (LFMC)
- f. Rigid Non-metallic conduit (PVC)

2.2 Surface Raceways:

- a. Surface Metal Raceways: Galvanized steel with snap-on covers complying with UL Manufacturer's standard enamel finish in color selected by Architect. Provide dividers as required to separate systems of different voltages.
 - Dual channel raceway used for data/electrical.
 - i. DS 4000, steel
 1. Downward Facing Connectivity for data outlets. Large bend radius for data cables and activations.
 - ii. Wiremold 6000, steel
 - Non-metallic raceway not allowed.
- b. Manufacturers: Subject to compliance with requirements, provide products by one of the following:
 - Wiremold / Legrand.
- c. Multi-Outlet Assembly (plugmold) not allowed.

2.3 Connections, Couplings and Fittings:

- a. GRC, IMC: Threaded rigid steel conduit fittings.
- b. EMT: Use setscrew (indoors) or compression (outdoors), steel fittings.
 - Steel concrete tight set screw type with insulated throats in connectors or steel watertight type.
 - Insulating bushings.

- Interior, steel only and no cast.

PART 3 – EXECUTION

3.1 Installation – Raceway Application

- a. Outdoors: Apply raceway products as specified below unless otherwise indicated:
 - Exposed Conduit: GRC or IMC.
 - Underground Conduit: RNC, Type Schedule-40- PVC, GRC, direct buried or concrete encased as indicated.
 - i. No PVC sweeps or elbows, metal only.
 - Minimum size of conduit is 3/4 ”
- b. Indoors: Apply raceway products as specified below unless otherwise indicated:
 - Exposed, Not Subject to Physical Damage: EMT.
 - Exposed and Subject to Physical Damage: GRC.
 - Concealed in Ceilings and Interior Walls and Partitions: EMT.
 - Connection to Vibrating Equipment (Including Transformers and Hydraulic, Pneumatic, Electric Solenoid, or Motor-Driven Equipment): FMC, except use LFMC in damp or wet locations.
 - Feeders over 600 V: GRC.
 - Damp or Wet Locations: GRC or IMC.
 - Minimum size of conduit is 3/4” for electrical circuits.
 - Minimum size of conduit is 1/2” for thermostat wiring or similar HVAC controls. This typically occurs when the control specifications require conduits to be installed per Division 26 requirements.
 - Do not install raceways in the concrete slab or under the slab on grade without approval of the University’s supervising electrician.
- c. Utility Tunnels & Electrical Vault Conduit:
 - Rigid Steel Conduit:
 - i. Standard pipe with threaded joints for electrical raceway use.
 - ii. Zinc coated by hot dip galvanizing or sherardizing.
 - iii. Manufacturers known to be acceptable: Allied Tube and Conduit; Triangle PWC Inc.; Western Tube & Conduit.
 - Union Joints for Rigid Steel:
 - i. Split coupling and unions are allowed.
 - ii. Running threads not allowed.
 - iii. Manufacturers known to be acceptable: O.Z. Gedney type SSP.
 - Conduit Sizing, Arrangement, and Installation:
 - i. Maintain minimum 6” clearance between conduit and mechanical piping.
 - ii. Coordinate installation with other trades.
 - iii. Maintain 12” clearance between conduit and heat sources such as flues, steam pipes and heating appliances.
 - iv. Provide No.12 AWG insulated conductor or suitable pull string in conduit, except sleeves and nipples.
 - Penetrations: Seal tunnel and vault penetrations with non-shrinking, vinyl reinforced, concrete sealant.
- d. Conduit Support:
 - Hanger spacing:
 - i. Do not exceed 8 feet on center.
 - ii. Provide a hanger adjacent to each outlet box.

- iii. Provide one hanger within 12 inches on each side of a change in direction.
 - Conduits are not permitted to be supported from ductwork, pipes, t-bar ceiling supports, or other systems foreign to electrical installation.
- e. Conduit Sizing, Arrangement, and Installation:
 - Use of metallic conduit is not sufficient for purposes of equipment safety grounding. All circuits regardless of the type of conduit shall be provided with a safety and equipment ground conductor.
 - Avoid moisture traps where able. Where unavoidable, provide junction box with drain fitting at conduit low point.
 - Avoid condensation between moist warm locations and cool locations by blocking end of conduit that may introduce air flow in conduit a material such as 'Duct Seal'.
 - At conduit transitions from different temperatures seal the box and/or conduit.
- a. Underground Duct Bank Installation:
 - Install conduit with minimum grade of 3-inches per 100-feet.
 - Terminate conduit in end bell at manhole entries.
 - Stagger conduit joints in concrete encasement 6-inches minimum vertically.
 - Use suitable separators and chairs installed not greater than 4-feet on centers. Band conduit together with suitable banding devices. Securely anchor conduit to prevent movement during concrete placement.
 - Provide minimum 3-inch concrete cover at bottom, top and sides of duct bank. Concrete to be dyed red.
 - Provide two No.4 steel reinforcing bars in top of bank under paved areas and within 5-feet of building, wall or vault penetration.
 - Conduit stub-ups to equipment shall be rigid steel extended a minimum of 10-feet outside building foundation and 5-feet outside outdoor concrete pads.
 - Terminate conduit with insulated grounding bushing.
 - Clearances between individual ducts:
 - i. For like services: Not less than 2-inches.
 - ii. For high voltage and signal services: Not less than 12-inches.
 - Upon completion of duct bank installation perform the following:
 - i. Pull a standard 12-inch long mandrel, 1/2" smaller than inside duct diameter through each duct.
 - ii. After each mandrel has been pulled, a brush with stiff bristles shall be pulled to remove loosened particles.
 - iii. Seal ducts at building entrances and outdoor equipment terminations with moisture resistant non-hardening compound.
 - iv. Provide plastic spacers to maintain clearances.
 - v. Provide non-ferrous tie wires to prevent duct displacement during pouring of concrete. Tie wires shall not act as substitute for spacers.

3.2 Interface with other products

- a. Not applicable.

3.3 Testing

- a. Not applicable.

3.4 Training

- a. Not applicable.

SECTION 26 05 34: Boxes

Document revision history: 08/2019 – Original Publication

Date	Section	Description of Change

PART 1 – GENERAL**1.1 Summary**

- a. Work included: Provision of materials and installation of:
 - Outlet Boxes
 - Floor Boxes
 - Cabinets
 - Enclosures

1.2 Submittals

- a. Product Data: For each box product indicated.

1.3 Qualifications

- a. UL 514A, Metallic Outlet Boxes

PART 2 – PRODUCTS**2.1 Outlet Boxes:**

- a. Manufacturers known to be acceptable for pressed steel boxes: Bowers; Raco; Steel City.
- b. Manufacturers known to be acceptable for cast metal boxes: Bell; T&B.

2.2 Floor Boxes:

- a. Manufacturers known to be acceptable for floor boxes: Legrand; FSR.
- b. Floor boxes are to accept standard wiring devices listed in specification section 26 27 26. Boxes requiring proprietary wiring devices are not allowed.
- c. Poke Through Boxes are not to be used in new construction.
- d. Poke Through Boxes, for remodel purposes only, shall not require special attachments to secure wiring devices. Devices and plates to be secured by screws. Model known to be acceptable is Wiremold 8" Evolution Series.

2.2 Cabinets and Enclosures:

- a. Manufacturers known to be acceptable: Circle AW; Hoffman; Rittal.
- b. Cabinets and enclosures include hinged and screwed cover enclosures and cabinets.
- c. All control boxes (lighting, auxiliary, fire alarm, etc.) and panels are to have hinged covers with door-in-door panels.
- d. Shop drawing submittals for equipment panels are to include wiring schematic diagram, wiring diagram, outline drawing, and construction diagram as described in ANSI/NEMA ICS 1.
- e. Hinged Cover Enclosures:
- f. Construction: NEMA 250; Type 1 steel; interior, dust type. Type 4 stainless steel in institutional and commercial kitchens and damp or wet locations.
 - Finish: Manufacturer's standard enamel finish.
 - Covers:
 - i. Continuous hinge.

- ii. Held closed by latch operable by key. Latch shall be capable of being keyed to cat 15.
- iii. Cat 70 keying required for all access to wiring and electrician access only.
- Back panel for mounting terminal blocks or electrical components: 14 gauge steel, white enamel finish.

PART 3 – EXECUTION

3.1 Installation

- a. Cabinets and Enclosures:
 - Shop assembled enclosures and cabinets housing terminal blocks or electrical components in accordance with ANSI/NEMA ICS 6.
 - Provide conduit hubs in exterior and wet locations and knockouts in interior dry locations.
 - Provide protective pocket inside front cover with schematic diagram, connection diagram and layout drawing of control wiring and components within enclosure.
- b. Outlet boxes to have pre-stamped knockouts.
- c. Outlet boxes shall be supported independent from the raceway system.
- d. Outlet boxes are to be sealed at exterior walls and as needed in other locations.
- e. Each device shall be provided with an outlet box.
- f. Sectional outlet boxes shall not be used.
- g. Fire Sprinkler/Smoke Supervision devices and their associated back boxes shall be by the same manufacturer.
- h. Surface mounted outlet boxes shall be utilized only in conjunction with exposed conduits, and shall be of the cast metal type with internal hubs and mounting flanges.
 - Exception: Exposed outlet boxes serving equipment connections in mechanical spaces and other unfinished areas may be pressed steel.

3.2 Interface with other products

- a. Provide labeling per Section 26 05 33, Identification of Electrical Systems.

3.3 Testing

- a. Not applicable.

3.4 Training

- a. Not applicable.

SECTION 26 05 53: Identification for Electrical Systems

Document revision history: 08/2019 – Original Publication

Date	Section	Description of Change

PART 1 – GENERAL

1.1 Summary

- a. Identification of power and control cables
- b. Identification for conductors
- c. Underground-line warning tape
- d. Equipment identification labels
- e. Identification of junction boxes for fire alarm cables

1.2 Submittals

- a. Product Data: For each electrical identification product indicated.

1.3 Qualifications

- a. Not applicable.

PART 2 – PRODUCTS

2.1 Electrical Identification:

- a. Materials:
 - Phenolic Nameplates
 - Cloth Wire Markers
- b. Wire & Cable Identification:

PART 3 – EXECUTION

3.1 Installation

- a. Shall follow ANSI Z535.4 – Safety Labels Construction.
- b. Labeling is to be reviewed and approved by the PM & FS Electrical Supervisor.
- c. Provide permanent signage, interior and exterior, at all utility boxes, vaults, manholes, etc.
- d. Zoned systems must be clearly defined and labeled.
- e. Covering or painting of any sign/label requires replacement.
- f. Mark and label new wiring and place in trays.
- g. Tag lighting feeds with circuit number and panel ID.
- h. If banks of switching are installed that control various systems (i.e. lighting, AV, and projection screen, etc.) or various spaces (i.e. classroom and corridor, etc.) labeling with 1/4" black letters indicating function of each switch is required.
- i. Panels require labeling of necessary PPE with potential hazards as a result of Arc Flash Hazard Analysis.
- j. Any item, component, equipment, etc. with a dual feed requires labeling at the device make-up box identifying each feed type and location.
- k. All J-boxes to be labeled with panel and circuit number with black sharpie.
- l. All junction boxes (not mounting boxes) containing fire alarm cables shall be labeled with a 2" x 3.5" adhesive backed label indicating the type and quantity of fire alarm circuits contained within the box. Contractor is to request and match a sample label from UO Safety and Risk Services.

- m. All switches and receptacles are to be labeled with the panel and circuit number that it is fed from. The labels are to be white or clear tape with 1/4" black lettering; lettering must provide legible contrast.
- n. All disconnects and electrical panels are to be labeled with 1/2" black lettering on Phenolic nameplates of white or the color specified below and must be fastened with sheet metal screws. In addition to the name the nameplate shall also include where the equipment is fed from.
- o. Fire Alarm: All circuit breakers, junction boxes, covers, etc. are to be labeled 'Fire Alarm' and red in color from the manufacturer. Except for circuit breakers, painted red is not acceptable.
- p. Emergency and/or Standby Power: Within occupied spaces all switches and receptacles shall have red devices, covers, plates, etc.
- q. Solar Power: Phenolic nameplates shall be yellow.
- r. UPS Power: Phenolic nameplates shall be blue.
- s. Grounded or Isolated Power:
 - Receptacles shall have orange covers, plates, etc.
 - Phenolic nameplates shall be orange.
- t. Wiring Devices – Labeling:
 - Taped label circuit numbers on conductors and neutrals at receptacles.
 - Plastic stick-on labels:
 - i. Identify device plates as indicated on drawings.
 - ii. Identify switch and receptacle plates with panel designation and circuit number.
 - iii. Identify disconnects to indicate equipment or device controlled.
- u. Torque logs are required at each service and/or distribution location to ensure good connections.

3.2 Interface with other products

- a. Section 26 24 13 Switchboards
- b. Section 26 24 16 Panelboards
- c. Section 26 05 34 Boxes
- d. Section 26 05 19 Low-Voltage Electrical Power Conductors
- e. Section 26 27 26 Wiring Devices
- f. Section 26 30 00 Automatic Transfer Switches
- g. Section 28 00 00 Fire Alarm

3.3 Testing

- a. Not applicable.

3.4 Training

- a. Not applicable.

SECTION 26 05 73: Electrical Distribution Systems Study

Document revision history: 08/2019 – Original Publication

Date	Section	Description of Change

PART 1 – GENERAL**1.1 Summary**

- a. Short Circuit Study
- b. Selective Coordination Study
- c. Arc Flash Assessment
- d. Arc Flash Labels

1.2 Submittals

- a. Distribution Study Report
- b. Arc Flash Labels
- c. ETAP electronic file

1.3 Qualifications

- a. The arc flash hazard analysis study shall be conducted under the responsible charge and approval of a Registered Professional Electrical Engineer skilled in performing and interpreting the power system studies:
 - The Registered Professional Electrical Engineer shall be an employee of the switchgear manufacture or a Professional Electrical Engineer of an approved engineering firm,
 - Engineer to be licensed in the state of Oregon, with a minimum of five (5) years of experience in performing power system studies.

PART 2 – PRODUCTS**2.1 Computer Software**

- a. Acceptable Software Manufacture's
 - Easy Power
 - ETAP
 - SKM
- b. The above manufacturer's are known to be acceptable for study purposes. However, at the completion of the project an electronic file of the study must be an ETAP file for incorporation into the University's campus wide data base. This file shall include all files required to edit and evaluate the electronic model, including libraries, one-lines, scenarios, TCC curves, and all reports.
- c. Each project is to have a unique building identifier for each and every named component created in the electronic one-line diagram. This unique identifier will allow for incorporation of the final model into the campus wide ETAP model. Coordinate with the University for the unique building identifier to be used for the project.

2.2 Arc Flash Labels

- a. Provide arc flash warning labels for all the equipment evaluated.
 - 4" x 4" thermal transfer type labels of high adhesion polyester.
 - Shall be printed by a thermal transfer type printer, with no field markings.
 - Shall be UV resistant material and smudge proof.
 - Shall be designed according to the following standards:

- i. UL969 – Standard for Marking and Labeling Systems
 - ii. ANSI Z535.4 – Product Safety Signs and Labels
 - iii. NFPA 70 (National Electric Code) – Article 110.16
- The overall color, top and bottom, of the arc flash hazard label shall vary depending upon the incident energy level.
 - i. YELLOW: $\leq 8 \text{ cal/cm}^2$
 - ii. TAN: $> 8 \text{ to } 12 \text{ cal/cm}^2$
 - iii. ORANGE: $> 12 \text{ to } 25 \text{ cal/cm}^2$
 - iv. MAGENTA: $> 25 \text{ to } 40 \text{ cal/cm}^2$
 - v. RED: $> 40 \text{ cal/cm}^2$
 - (Refer to the following sample arc flash hazard label, with a yellow boarder for $\leq 8 \text{ cal/cm}^2$)

PART 3 – EXECUTION

3.1 System Studies

- a. Study requirements
 - New building construction requires a system study.
 - Major renovation of an existing building requires a system study. All existing equipment that will remain is to be included in the study.
 - For small renovations check with the University to determine whether or not a study is required.
 - Where renovations result in the replacement of existing equipment that affects the result of a previous study a new study will be required for the entire system.
- b. Data Collection
 - The contractor shall be responsible for the collection of all data necessary for all calculations used in the study.
 - Where existing equipment is included as part of the study the contractor shall field verify all equipment and not rely upon existing one-line diagrams or a previous study for information.
 - Provide corrections to the electrical one-line diagram to reflect changes discovered during the study.
 - For buildings fed from the campus' electrical distribution system obtain information from the University regarding system three-phase short circuit MVA and X/R ratio along with impedances of any transformers that are furnished by the University.
- c. Short-Circuit Study
 - Short Circuit study to be completed prior to the ordering equipment.
- d. Coordination Study
 - Perform coordination study with the aid of a computer program. Prepare a written report using results of Short-Circuit study. Comply with IEEE 399.
 - i. Instantaneous for normal power shall be a 0.1 second threshold.
 - ii. Emergency power and legally required standby systems shall be a 0.01 second threshold.
 - iii. Optional Standby power shall be a 0.02 second threshold.
 - The coordination study shall include overcurrent protection devices included in both the normal, standby and emergency systems.

- e. Arc Flash Hazard Analysis
- The arc flash hazard analysis shall be performed according to the IEEE 1584 equations that are presented in NFPA70E-2015, Annex D. The arc flash hazard analysis shall be performed in conjunction with the short-circuit analysis and the protective device time-current coordination analysis.
 - The flash protection boundary and the incident energy shall be calculated at the following locations in the electrical distribution system:
 - i. Switchgear and switchboard buses.
 - ii. Primary and secondary side of oil filled, medium voltage transformers.
 - iii. Medium-voltage buses.
 - iv. Motor-control centers.
 - v. Distribution panel-boards.
 - vi. Branch circuit panel-boards.
 - Arc Flash calculations shall be based on actual overcurrent protective device clearing time. A maximum clearing time of 2 seconds will be used based on IEEE 1584-2002 section B.1.2. Where it is not physically possible to move outside of the flash protection boundary in less than 2 seconds during an arc flash event, a maximum clearing time based on the specific location shall be utilized.
 - The preliminary Arc Flash study must be completed prior to energizing any medium voltage transformers. The University will not energize the transformer without the study being complete.
- f. Arc Flash Labels
- Floor Standing Equipment: Labels shall be provided on the front of each individual section. Equipment requiring rear and/or side access shall have labels provided on each individual section access area. Equipment line-ups containing sections with multiple incident energy and flash protection boundaries shall be labeled as identified in the Arc Flash Analysis table.
 - Wall Mounted Equipment: Labels shall be provided on the outside of the front cover, centered at the top.
 - General Use Safety labels shall be installed on equipment in coordination with the Arc Flash Labels. The General Use Safety labels shall warn of general electrical hazards associated with shock, arc flash, and explosions, and instruct workers to turn off power prior to work.
- g. Adjustable Circuit Breaker Settings
- All adjustable circuit breaker settings, new or existing, shall be set by the contractor according to the recommendations included in the final report.
 - Final settings will be witnessed by University personnel. The contractor shall remove all covers that obscure any adjustable trip settings. Witnessing will be completed with the equipment de-energized. The contractor is responsible for notifying the University when they are ready for the witnessing to occur.

3.2 Interface with other products

- a. Provide labeling per Section 26 05 33, Identification of Electrical Systems.

3.3 Testing

- a. Not applicable.

3.4 Training

- a. Not applicable.

Typical label, with yellow highlighted border, for an incident energy level which is: $\leq 8 \text{ cal/cm}^2$. See above for additional color coding requirements.

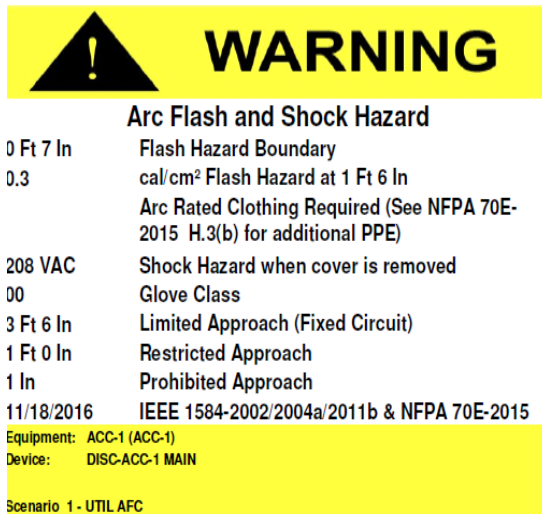

WARNING

Arc Flash and Shock Hazard

0 Ft 7 In	Flash Hazard Boundary
0.3	cal/cm ² Flash Hazard at 1 Ft 6 In
	Arc Rated Clothing Required (See NFPA 70E-2015 H.3(b) for additional PPE)
208 VAC	Shock Hazard when cover is removed
00	Glove Class
3 Ft 6 In	Limited Approach (Fixed Circuit)
1 Ft 0 In	Restricted Approach
1 In	Prohibited Approach
11/18/2016	IEEE 1584-2002/2004a/2011b & NFPA 70E-2015

Equipment: ACC-1 (ACC-1)
Device: DISC-ACC-1 MAIN

Scenario 1 - UTIL AFC

SECTION 26 51 00: Digital Lighting Controls

Document revision history: 08/2019 – Original Publication

Date	Section	Description of Change

PART 1 – GENERAL**1.1 Summary**

- a. Work included: Provision of materials and installation of:
 - Control Module (Gateway)
 - Communication Bridges
 - Digital Occupancy Sensors
 - Digital Wall Switches/Dimmers
 - Digital Photosensors
 - Digital Power Packs

1.2 Submittals

- a. Product Data: For each type of device
- b. Shop drawings: Produced by the manufacture with devices shown accurately located on the drawings. Wiring diagrams, for all devices and spaces, to be included on the drawings.

1.3 Qualifications

- a. Installer shall have a minimum of 5 years of full time experience in the installation and maintenance of lighting control systems. Installer staff shall be factory trained and certified; documentation required. Warranty repair response time: 4 hours maximum.

PART 2 – PRODUCTS**2.1 Digital Lighting Control System**

- a. Manufactures known to be acceptable: N-Light, Wattstopper DLM
- b. System shall be remotely programmable via network connection

2.1.1 Digital Occupancy/Vacancy Sensor

- a. Passive Infra-red
- b. Dual Technology
- c. Ultrasonic

2.1.2 Digital Wall Switches

- a. Low voltage momentary push button
- b. 0-10 volt Dimming

2.2 Digital Photo Sensor**2.3 Digital Relay**

- a. Discrete relay for HVAC controls.

2.4 Cables

- a. Cat 5e

2.5 Spare Parts

- a. Digital Occupancy Sensor (3)
- b. Digital Wall Switch (3)
- c. Digital Power Pack (5)

PART 3 – EXECUTION

3.1 Installation

1. Lighting Control

- a. All devices are to be integrated together. Stand alone systems for individual spaces is not acceptable.
- b. Interior spaces without exterior windows such as open/private offices, conference rooms and meeting rooms where occupancy sensors are installed in conjunction with switches the system shall operate in manual on, automatic off mode. Time out period for occupancy sensor shall be 20 minutes.
- c. Interior spaces with exterior windows such as open/private offices, conference rooms and meeting rooms where occupancy sensors are installed in conjunction with switches the system shall operate in manual on, automatic off mode. Time out period for occupancy sensor shall be 20 minutes.
- d. Dimming to a minimum of 10%. Dimming to 1% for classrooms, conference rooms and other areas with flat panel monitors and projector screens. Dimming to 0.1% as required by lighting design.
- e. Light output high end trim to be set to 90%
- f. Enclosed stairwell luminaires are to be controlled by occupancy sensors. When no motion is sensed for 15 minutes luminaires are to be dimmed to at least 50% output. Stairwells are to be illuminated at all times.
- g. Large ganged restrooms shall have a minimum of 2 occupancy sensors. Time out period for occupancy sensor shall be 15 minutes.
- h. Hallways, corridors and similar spaces to be controlled with time schedules during normally occupied hours. During unoccupied hours lights are to be controlled by occupancy sensors rather than over ride switches. Time out period for occupancy sensor shall be 15 minutes.
- i. Lab spaces with occupancy sensors shall operate in automatic on/off mode. Time out period for occupancy sensor shall be 30 minutes. In general one occupancy sensor shall be provided in each isle of a peninsula/island work bays. Sensors to be mounted on a pendant below the lowest obstruction such as HVAC duct or water pipes.
- j. Occupancy sensors to be ceiling mounted. Avoid the use of switches with integral occupancy sensors except in small rooms such as custodial closets and single occupant bathrooms.
- k. Occupancy sensors in open and private offices, conference rooms, meeting rooms and other similar spaces to have quantity of occupancy sensors based upon small hand motion for activation.

2. Daylight Controls

- a. Provide daylighting controls as required by Oregon Energy Efficiency Specialty Code or to meet energy levels as defined by the project's energy model.
- b. Daylight controls are not allowed in individual offices.

3. Exterior Lighting Controls

- a. Exterior lights are not to be controlled by this system. Exterior lights to be controlled via an exterior photocell and lighting contractors. Bypass capability, for testing purposes, is required for all exterior lighting.

4. Integral Relay for HVAC Control:

- a. Occupancy sensors to be provided with a relay. Note to electrical designer: Wattstopper digital occupancy sensors do not have an integral relay. A discrete relay must be specified when the HVAC system monitors the space for occupancy through activation of the occupancy sensor.

3.2 Interface with other products

- a. Section 26 51 00 Interior Lighting
- b. Section 26 05 53 Identification for Electrical Systems

3.3 Testing

- a. System shall be fully commissioned prior to acceptance.

3.4 Training

- a. Training is to occur no sooner than 1 week following complete system set up by factory trained technician.
- b. A minimum of 1hr overview training for the key building occupants (to be determined by project) regarding everyday use is required with any lighting system. This can be increased based upon complexity or scope of the lighting system(s).
- c. A minimum of 4 hours FS Electrician training is required with any lighting system to a maintenance and service level. This can be increased based upon complexity or scope of the lighting system(s).

3.5 Adjusting

- a. Occupancy Adjustments: When requested within 12 months of Substantial Completion, provide on-site assistance in adjusting system to suit actual occupied conditions. Provide up to two visits to Project during other-than-normal occupancy hours for this purpose. These visits are in addition to visits required due to warranty work or work required for proper operation of the system.

SECTION 26 22 00: Low Voltage Transformers

Document revision history: 08/2019 – Original Publication

Date	Section	Description of Change

PART 1 – GENERAL**1.1 Summary**

- a. Work Included: Provision of materials, installation and testing of
 - Dry Type Transformers

1.2 Submittals

- a. Product Data
 - For each transformer indicated.

1.3 Qualifications

- a. UL 1561: Dry-Type General Purpose and Power Transformers.
- b. DOE 2016 or latest Oregon energy efficiency requirement.

PART 2 – PRODUCTS**2.1 Switchboards:**

- a. Manufactures
 - Square D; Siemens; GE; Eaton
- b. Construction
 - Windings: Copper
 - Insulation and winding temperature
 - i. Class 220 with 115 degrees C rise.
 - Compression lugs for copper conductors.

PART 3 – EXECUTION**3.1 Installation**

- a. Provide vibration isolation pads.
- b. Mounting
 - Floor mounted
 - Wall mounted 45 kva or less with prior approval from the University. All wall mounted equipment must be approved by the design team structural engineer.
 - Stacked transformers must maintain the manufactures recommended clearances between transformers ensuring that adequate ventilation and heat dissipation is provided.
- c. Provide housekeeping pad that extends 4” beyond the foot print of the transformer.
- d. Torque logs are required at each transformer location to ensure good connections.

3.2 Interface with other products

- a. Labeling per Section 26 05 33, Identification of Electrical Systems.

3.3 Testing

- a. Provide testing per NETA STD ATS, Section 7.2.1.

3.4 Training

- a. Not applicable.

SECTION 26 24 13: Switchboards

Document revision history: 08/2019 – Original Publication

Date	Section	Description of Change

PART 1 – GENERAL**1.1 Summary**

- a. Work Included: Provision of materials, installation and testing of:
 - Switchboards
 - Circuit Breakers

1.2 Submittals

- a. Design Submittal
 - Provide documentation during the design phase at least one manufacture has reviewed and acknowledged they can meet requirements for selective coordination of emergency and standby systems. See Arc Flash Study per Section 26 05 73 for time requirements for coordination.
 - Basis of design manufacture meeting requirements above to be noted on the drawings and specifications.
 - Recommend not indicating circuit breaker frame sizes, show trip only, for emergency system and standby system.
- b. Product Data
 - For each switchboard indicated.
 - For each type of circuit breaker.
 - OEM submittal of existing switchboard when a new electrical meter is integrated into the existing switchboard.

1.3 Qualifications

- a. UL 891, Switchboards

PART 2 – PRODUCTS**2.1 Switchboards:**

- a. Manufactures
 - Square D; Siemens – No exceptions allowed. These are the only know manufactures that are compatible with the campus standard ION metering system.
- b. Switchboard Construction
 - Copper bus-bar panels only.
 - Bolt-a-buss breakers only.
 - Copper wiring only.
 - Compression lugs for copper conductors.
- c. Circuit Breakers
 - Fully rated; series rating is not acceptable
 - Molded case circuit breakers
 - Solid-State molded case circuit breakers.
 - The service entrance switchboard, normal and standby systems, shall have a main circuit breaker. Use of the 6 disconnect rule is not allowed.
 - Sub-distribution switchboards shall have a main circuit breaker if not located in the same room as the equipment feeding it.

- d. Main-Tie-Main Circuit Breakers
 - Insulated Case Circuit Breakers
 - Electrically operated
 - Primary mode of operation is Closed Transition. Secondary mode of operation is Open Transition
 - Manually operated kirk-key systems are not allowed.

PART 3 – EXECUTION

3.1 Installation

- a. Science Buildings and Data Centers to have switchboards with Main-Tie-Main circuits. Each end to be fed from transformers fed from separate medium voltage campus feeders. AIC rating of the system is to be less than 65K AIC where feasible.
- b. Phase Rotation
 - The phase conductors feeding each switchboard shall have a clockwise rotation.
- c. Provide a minimum of 3 spare circuit breakers and 3 prepared spaces in each switchboard. Size of spare circuit breakers to range from 125 -225 amps unless there is a known need for a future expansion requiring larger circuit breakers.
- d. The main switchboard and sub-distribution switchboards shall be located in dedicated electrical rooms.
- e. Provide a housekeeping pad under each switchboard.
- f. Torque logs are required at each service and/or distribution location to ensure good connections.

3.2 Interface with other products

- a. Labeling per Section 26 05 33, Identification of Electrical Systems
- b. Electrical meters per Section 33 70 01. Where new meters are installed in existing switchboards the OEM must provide documentation of the modifications required to integrate the new electrical meter into the existing switchboard.
- c. Short circuit / Coordination / Arc Flash Study per Section 26 05 73

3.3 Testing

- a. Provide testing per NETA STD ATS, Section 7.1
- b. Clockwise Phase Rotation to be tested and documented. Provide documentation of correct phasing for each switchboard.

3.4 Training

- a. Not applicable.

SECTION 26 24 16: Panelboards

Document revision history: 08/2019 – Original Publication

Date	Section	Description of Change

PART 1 – GENERAL**1.1 Summary**

- a. Work Included: Provision of materials, installation and testing of:
 - Panelboards
 - Circuit Breakers

1.2 Submittals

- a. Product Data for each Panelboard and circuit breaker type.

1.3 Qualifications

- a. UL 67, Standards for Panelboards

PART 2 – PRODUCTS**2.1 Panelboards:**

- a. Manufactures
 - Square D; Siemens – For new construction or remodels where new ION metering system is being provided. These are the only know manufactures that are compatible with the campus standard ION metering system.
 - Square D; Siemens; GE; Cutler Hammer – For remodels where ION metering system is not required for the project.
- b. Panelboard Construction
 - Copper bus-bar panels only.
 - Bolt-a-buss breakers only.
 - Copper wiring only.
 - Do not paint panel covers.
 - Hinged outer trim, door-in-door construction..
 - Cat 60 or 70 keying
- c. Circuit Breakers
 - Fully rated; series rating is not acceptable.
 - Molded case circuit breakers.
 - Circuit breakers for fire alarm control equipment have a red handle.
- d. Fuses
 - Fusible Panelboards for selective coordination are not allowed.

PART 3 – EXECUTION**3.1 Installation**

- a. All panel schedules are to be included on the electrical drawings. Including the panel schedules are part of the specifications is not allowed.
- b. Phase Rotation
 - The phase conductors feeding each Panelboard shall have a clockwise rotation.

- c. Spare Capacity
- 20% spare capacity/breaker positions in each Panelboard is required at the end of CD's.
 - Populate all unused positions with spare circuit breakers in 208 volt panelboards fed from the optional standby system.
- d. Each panel is to be fed from a separate feeder that originates in the main distribution switchboard or a sub-distribution switchboard. Feeding one panel from another, whether by feed-thru lugs or a circuit breaker, is not allowed.
- e. Provide a main circuit breaker for each panel that is not in the same room as the switchboard feeding it.
- f. For recessed panels provide a minimum of three extra and empty ¾" conduits, stubbed to above an accessible ceiling, for every panel for future use.
- g. Panels to be located in a dedicated electrical room. Not to be located in classrooms, offices, hallways, etc. Panels may be located in individual labs but are to serve no equipment outside of the lab area.
- h. Mounting Height for Panel-boards: Top = 72 inches (top of fixture dimension)
- i. Circuit directory to reflect final circuiting conditions and room numbers. Panel directory shall be completed using a UO template and be printed with UO header. The template will be furnished to the contractor for their use.
- For existing panels provide a new circuit directory including new circuits and existing circuits. Existing circuit information to be obtained from the existing directory card.
- j. Circuit directory to reflect circuiting changes required to balance phase loads.
- k. Panel doors in main electrical rooms opposite and/or beside equipment shall open unobstructed and clear each other.
- l. Circuit breakers serving the fire alarm must have tamper proof device and locked in the "On" position.
- m. Electrical Panels in new construction are to be labeled as follows:

First Character – Floor Level	Second Character – Type of Power	Third Character – Panel Number	Required Dash	Fourth Character – Voltage	Resulting Panel Name
B – Basement	N – Normal	1 – 1 st Panel on Floor Level	-	2 – 120/208v	BN1-2
1 – 1 st Floor	S – Standby	2 – 2 nd Panel on Floor Level	-	4 – 277/480v	1S2-4
2 – 2 nd Floor	E – Emergency	3 – 3 rd Panel on Floor Level	-	2 – 120/208v	2E3-2
3 – 3 rd Floor	V – Voltaic	4 – 4 th Panel on Floor Level	-	4 – 277/480v	3V4-4
4 – 4 th Floor	I – Inverter or UPS	5 – 5 th Panel on Floor Level	-	2 – 120/208v	4I5-2
P – Penthouse	N – Normal	6 – 6 th Panel on Floor Level	-	4 – 277/280v	PN6-4

- n. Remodel construction that adds electrical panels fed from an existing panel are to be labeled as follows...

Existing Panel Name (Example)	Required Dash	Added Character	Resulting Name for New Panel
BN1-2	-	A – 1 st new panel fed from existing	BN1-2-A
BN1-2	-	B – 2 nd new panel fed from existing	BN1-2-B

3.2 Interface with other products

- Provide labeling per Section 26 05 33, Identification of Electrical Systems
- Short circuit / Coordination / Arc Flash Study per 26 05 73

3.3 Testing

- Provide testing as outlined in the commissioning of electrical systems
- Clockwise Phase Rotation to be tested and documented. Provide documentation of correct phasing for each Panelboard.

3.4 Training

- Not applicable.

SECTION 26 27 26: Wiring Devices

Document revision history: 08/2019 – Original Publication

Date	Section	Description of Change

PART 1 – GENERAL**1.1 Summary**

- a. Work Included: Provision of materials, installation and testing of:
- Receptacles
 - Wall Switches
 - Finish Plates
 - Occupancy Sensors

1.2 Submittals

- a. Product Data for each wiring device product indicated.

1.3 Qualifications

- a. UL 498 – Standard for Attachment Plugs and Receptacles
b. UL 943 – Standard for Safety for Ground Fault Circuit Interrupters

PART 2 – PRODUCTS**2.1 Receptacles**

- a. Convenience and straight-blade receptacles are to be 20 amp, specification grade, at a minimum.
b. Emergency and/or Standby Power: Receptacles to be red
c. Grounded or Isolated Power: Receptacles to be orange
d. No pre-fabricated or pre-wired plug mold.
e. Manufacturers known to be acceptable for isolated ground receptacles: Hubbell IG-5362, 20 Amps, 120 Volt; Leviton.
f. All receptacles must be taped or insulated.
g. Receptacles with snap on pigtail connectors are not allowed and should be specifically identified in the specifications as not allowed.

2.2 Wall Switches

- a. Switches to be 20 amp specification grade, at a minimum.
b. Switches with snap on pigtail connectors are not allowed and should be specifically identified in the specifications as not allowed.

2.3 Finish Plates

- a. Nylon or 302 Stainless Steel. No plastic finish plates
b. Emergency and/or Standby Power: Finish plate to be red
c. Grounded or Isolated Power: Finish plates to be orange

PART 3 – EXECUTION**3.1 Installation**

- a. All switches must have a neutral wire pulled.

- b. Office receptacles are to be located, one on each of 2 opposite side walls, away from the door, where office desks will be located. A minimum of 3 receptacles per room. Provide additional receptacles as needed for very large offices. Provide one circuit for every 2, average sized, offices.
- c. Convenience outlets for laptops are to be located within public spaces at reasonable locations.
- d. Receptacles for convenience and FS Custodial should be located near building entrances, on exterior balconies, proper, and in elevators.
- e. At all ceiling hung equipment, provide a service receptacle at the equipment disconnect.
- f. Install vertical receptacles with ground plug down.
- g. Horizontally mounted receptacles are not allowed, except when they are installed in a surface mounted raceway. When installed horizontally the ground plug is to be to the left, so the grounded conductor plug is on top.
- h. Wall mounted, 120 volt, switch with integral occupancy sensor may be used in small rooms such as restrooms, storage closets, etc.
- i. Ceiling mounted, 120 volt, occupancy sensors are not allowed.
- j. Stainless steel faceplates should be used in all lab and research buildings.

3.2 Interface with other products

- a. Provide labeling per Section 26 05 33, Identification of Electrical Systems

3.3 Testing

- a. Test receptacles for polarity; Neutral-ground, Neutral-hot, Ground-hot.
- b. Test receptacles for faults; Line-neutral, Line-ground, Neutral-ground.

3.4 Training

- a. Not applicable.

SECTION 26 30 00: Automatic Transfer Switches

Document revision history: 08/2019 – Original Publication

Date	Section	Description of Change

PART 1 – GENERAL**1.1 Summary**

- a. Switches for use on standby and life-safety systems shall be closed transition with bypass isolation and shall have phase sensing and monitoring relays.
- b. Switch status shall be display locally at the ATS and remotely at the CPS dashboard located at the Central Power Station.

1.2 Submittals

- a. Product Data: For each type of product indicated. Include rated capacities, weights, operating characteristics, furnished specialties, accessories and seismic qualification certificate.
- b. Shop Drawings: Dimensioned plans, elevations, sections and details showing minimum clearances, conductor entry positions, etc.

1.3 Qualifications

- a. UL 1008 Automatic Transfer Switch

PART 2 – PRODUCTS**2.1 Automatic Transfer Switch**

- a. Manufacturers known to be acceptable are as follows: Russell; ASCO; GE/Zenith
 - Unless otherwise noted in the Owner's Project Requirements (OPR) the basis of design shall be ASCO.
- b. Closed Transition
 - Isolation By-Pass, draw out type to allow for field maintenance on the ATS while still maintaining power to building loads.
 - 4-pole, with switched neutral
 - Electrically operated, mechanically held
- c. Accessories
 - Inhibit transfer to emergency power
 - Inhibit transfer to normal power

2.2 Enclosure

- a. Indoor locations: NEMA Type 1
- b. Provide lockable door. Access into the enclosure shall be from the front. Avoid equipment that requires side or rear access.
- c. All relays, timers, control circuitry, and accessories shall be visible and traceable from the front of the enclosure. Control devices that change state shall be mounted so that their state can be visually determined without the aid of instruments.

2.3 Monitoring and Annunciation of Automatic Transfer Switch Status

- a. Status Contacts:
 - Provide 2 sets of Form 'C' contacts for remote monitoring of ATS status for each of the positions noted below.
 - Provide contacts for the following:
 - i. Normal Power Available.
 - ii. Emergency Power Available.
 - iii. ATS on Normal Source.
 - iv. ATS on Emergency Source.
 - v. 2 Spare

PART 3 – EXECUTION

3.1 Installation

- a. Short Time Rating
 - Design a system around a 3-cycle withstand current rating. Avoid designs requiring 18-cycle and 30-cycle withstand current ratings to achieve selective coordination.
- b. Upon a sustained drop in voltage of 80% in any phase of the normal power source from rated voltage and after a delay of 7 seconds for standby power and 5 seconds for emergency power, switch shall transfer the load to the emergency power source provided the voltage and frequency of that source are at least 90% of rated value. Upon return of normal power to within 10% of rated voltage on all phases, and after a preset time delay adjustable from 2 to 25 minutes, the switch shall automatically transfer the load to the normal source.
- c. Transfer switch shall have a zero to six-second adjustable time delay off position between source transfers to insure residual voltage decay from motors and transformers.
- d. If the emergency power source shall fail during the generator delay period prior to return to normal source, the time delay shall bypass and the switch shall return to normal source, the time delay shall bypass and the switch shall return immediately to the normal source.
- e. An override switch shall provide to bypass the automatic transfer controls so that the transferred switch will remain indefinitely connected to the emergency power source, regardless of the condition of the normal power source.
- f. Identify all control wire terminations by tubular sleeve type markers to agree with wire marking identification on manufacturer's equipment drawings.
- g. Provide contacts and terminals required to provide remote control and monitoring by the CPS monitoring and control system.
- h. Execution
 - Adjust all timing controls and parameters and provide. A set-up sheet of final settings inside the enclosure.
- i. Provide a housekeeping pad beneath each ATS.

3.2 Interface with other products

- a. Electrical meters per Section 33 70 01,
- b. Short circuit / Coordination / Arc Flash Study per Section 26 05 73
- c. Provide labeling per Section 26 05 33, Identification of Electrical Systems
 - Nameplates shall identify all equipment, operating handles, and devices with engraved plastic laminated nameplates. Nameplates will be red background with white lettering. Engraving shall identify equipment and supply sources to match nomenclature identification shown on equipment schematic and wiring diagrams.

3.3 Testing

- a. Electrical Testing Required & Contractor Checklist: ANSI/NETA ATS-2009 and NFPA 70E. The below references refer to Copyrighted *2009 ANSI/NETA Standard for Maintenance Testing Specifications*
InterNational Electrical Testing Association
3050 Old Centre Ave., Suite 102 Portage, MI 49024
Phone: 269-488-6382 | Fax: 269-488-6383
www.netaworld.org
 - Transfer switch testing: Chapter 7.22.3
- b. Installation and start-up will be supervised, checked and tested by a qualified representative of the equipment manufacture.
- c. Demonstrate operation of transfer switch in the presence of the FS Electrical Supervisor & CPS Electrical Supervisor and Commissioning Agent by operating normal power source under load and verifying transfer switch transfers to alternate source and back to normal source after normal power is restored.
- d. Verify that the transfer switch status and source availability are enunciated properly at the ATS and remotely at the CPS Dashboard located at the central power station.

3.4 Training

- a. Provide a minimum of 4 hours of operation and maintenance training on site for FS personnel. Include troubleshooting, repair and maintenance manuals for each participant. The instructor shall be the manufacturer's authorized representative.
- b. Training session shall be a minimum of 2 weeks after testing and the system is functionally operating.

SECTION 26 51 00: Interior Lighting

Document revision history: 08/2019 – Original Publication

Date	Section	Description of Change

PART 1 – GENERAL**1.1 Summary**

- a. Work included: Provision of materials and installation of:
 - Luminaires
 - LED Lamps
 - LED Drivers
 - Emergency Fixtures
- b. Illumination Target Levels
 - Open Offices 30 fc
 - Private Offices 30 fc
 - Conference Rooms 30 fc
 - Corridors 15 fc
 - Classrooms 40-45 fc
 - Labs
 - i. Ambient Lighting: 50 fc
 - ii. Lab benches: 70+ fc, with supplemental task lights, when required by the project.

1.2 Submittals

- a. Product Data: For each type of fixture.

1.3 Qualifications

- a. UL 8750 - Standard for Light Emitting Diode (LED) Equipment for Use in Lighting Products

PART 2 – PRODUCTS**2.1 Luminaires**

- a. Unless otherwise approved all fixtures will have 0-10 volt, dimmable, LED lamps.
- b. Tunnel luminaire to be a vandal proof LED fixture with damp listing.

2.2 LED Drivers

- a. Manufactures known to be acceptable: eldoLED Series, Advance/Phillips, Osram Sylvania
- b. 0-10 volt, dimming
- c. Warranty: 5 years

2.3 LED Lamps

- a. Manufactures known to be acceptable: Nichia, Cree, Osram Sylvania, GE Lumination
- b. Color Rendering Index (CRI) to be greater than or equal to 80
- c. Color Temperature:
 - 3000- 4000 K
- d. Lamp Life: 50,000 hours
- e. Warranty: 5 years

2.4 Emergency Fixture

- a. Acceptable Products
 - Integral batteries installed in general illumination fixtures are not allowed.
 - Emergency Lighting Inverters to provide power for multiple fixtures are not allowed.
 - Where there is no life safety system fed from the University standby power distribution system Unit Emergency Lights (bugeyes) will be used throughout the egress path. Fixtures similar to Concealite may be used where there is a need to hide the fixture from view.

2.5 Exit Signs

- a. Green LED lamps.
- b. No radioactive materials allowed.
- c. Photo luminescent exits are allowed in locations where sufficient light already exists. Not allowed if additional light must be provided to power photo luminescent.

2.6 Spare Parts

- a. Provide 3 spare LED drivers for each LED luminaire type.

PART 3 – EXECUTION

3.1 Installation

- a. Use of remote mounted drivers for LED fixtures must be reviewed and approved by UO Facility Services Supervising Electrician.
- b. Lighting above suspended ceilings for equipment access and serviceability is required. Owner is to decide where access is required.
- c. Exterior balconies must be well lit for personal safety as well as use in the evening hours by UO Custodial.
- d. Integrated lighting into casework requires prior FS Electrician review and approval.
- e. Lighting design and placement must allow access to drivers and lamps for the purpose of replacement and maintenance without damage to surrounding finishes, equipment, etc.
- f. Light fixtures are not to be installed above stair steps. Locate fixtures at the landings, wall mounted is preferable.
- g. Track lighting is allowed only with prior review by FS Electrician and Utility & Energy PM and approval.
- h. Emergency lighting units and exit signs are to be on a dedicated circuit not to impact computers, equipment, etc. during exercising and/or charging of batteries.
- i. Provide individual control of groups of fixtures without the use of pre-sets.
- j. For auditorium style classrooms coordinate with UO CMET to incorporate lighting controls through media cabinets and not wall mounted.

3.2 Interface with other products

- a. Section 26 09 25 Digital Lighting Controls

3.3 Testing

- a. Not applicable.

3.4 Training

- a. Not applicable.

SECTION 26 56 00: Exterior Lighting

Document revision history: 08/2019 – Original Publication

Date	Section	Description of Change

PART 1 – GENERAL**1.1 Summary**

- a. Work included: Provision of materials and installation of:
 - Exterior Luminaires
 - Poles
 - In-ground pull boxes
 - Egress path illumination

1.2 Submittals

- a. Product Data: Provide for each type of product provided

1.3 Qualifications

- a. Not applicable.

PART 2 – PRODUCTS**2.1 Site Security Lighting**

- a. Owner Furnished Contractor Installed (OFICI) Light Posts, Lamps, and Luminaries for information and reference only: Visco, 42B Series with Acorn top, 4000 lumens.

2.2 Parking Lot Lighting

- a. LED lamp.
- b. Pole height shall be no more than 25ft.

2.3 Site Lighting

- a. Locations will be identified during design.
- b. Glare-control / light-trespass issues must be addressed submitting photo metrics to demonstrate compliance.
- c. Lighting control by photocell.

PART 3 – EXECUTION**3.1 Installation****3.1.1 Site Lighting**

- a. Light Poles
 - Junction boxes shall be installed adjacent to exterior post lights.
 - One tenon adapter per fixture/pole with a 1/4" 20 thread set screw to fasten the adapter to the tenon; not noted in the detail below.
 - 120 volt power only
 - Light pole bases will be anchored.

- Light pole base may have an optional 120-volt receptacle with welded adapter. This receptacle access is to be either (1) a keyed cover, or (2) labeled with panel and circuit location to be turned on and off by appropriate personnel as needed.
- Space campus standard light posts 60-65 feet apart.
- b. LED lamps only.
- c. Glare-control / light-trespass issues must be addressed. Consultant shall submit photo metrics to demonstrate compliance.
- d. Circuiting and control of walkway lighting shall be from individual buildings and controlled by central photocells mounted on the building. All exterior lights are to be routed through a lighting contactor, with bypass switch for testing purposes, which is controlled by the photocell. Exterior lights are not to be controlled with a time clock function.
- e. Bypass capability in the circuitry is required for ALL exterior lighting.
- f. Photocell over-ride is required with a manual and mechanical over-ride.
- g. Aim fixtures at completion of project, as appropriate to address glare control and light trespass issues.
- h. Reference CPFM policies and Campus Outdoor Lighting Plan.
- i. Site placement of light poles and trenching for light poles is to be coordinated with tree locations and FS Exterior staff.
- j. Avoid building mounted light fixtures where possible.
- k. Provide a 1" conduit from the pole base, stubbed out 5' from the base, and capped for future use.

3.1.2 Egress Path and Security Lighting

- a. Building exterior egress path to be illuminated to 1 footcandle.
- b. Sidewalks to be illuminated to 1 footcandle.

3.2 Interface with other products

- a. Provide labeling per Section 26 05 53, Identification of Electrical Systems

3.3 Testing

- a. Not applicable.

3.4 Training

- a. Not applicable.

- Underground J-box detail 'Carson' 1419-12-4YE

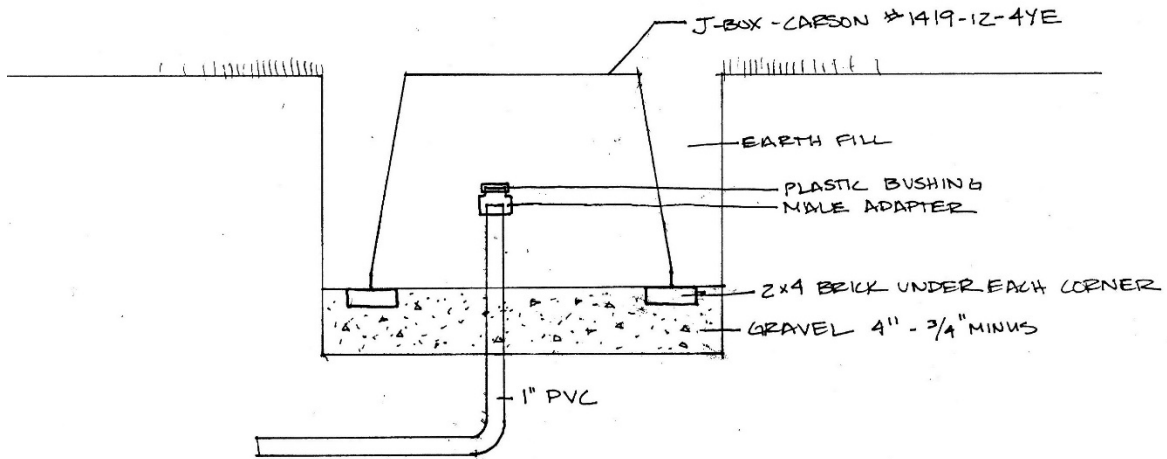

- Plan view detail of Mow slab for pole light base in lawn conditions adjacent to sidewalks:

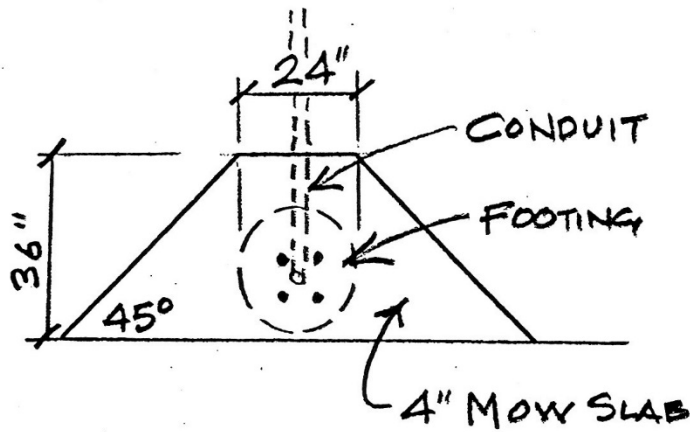

MOW SLAB FOR POLE
LIGHT BASE IN LAWN

Section 26 50 00 – Lighting continued

- Basis of design for light pole foundation; consultant review and detailing per project is still required: detail by M.R.Richards Engineering, revised 4-2-2009.

MRR
M. R. RICHARDS ENGINEERING INC
 99 WEST 10th AVENUE SUITE 395 EUGENE OR 97401
 541-687-0129 FAX 541-687-0133

PROJECT LIGHT POLE FOUNDATION
 UNIVERSITY OF OREGON
CALCULATED BY MRR
DATE 10-21-04 **PAGE**
 4-2-09 **REVISED**



MATERIALS:

- CONCRETE - $f'_c = 2500$ PSI MIN
 4 - 6% AIR
- REBAR - ASTM A315
 $f_y = 60$ KSI
- ANCHOR BOLTS
 - ASTM A36
 - H.D. GALV

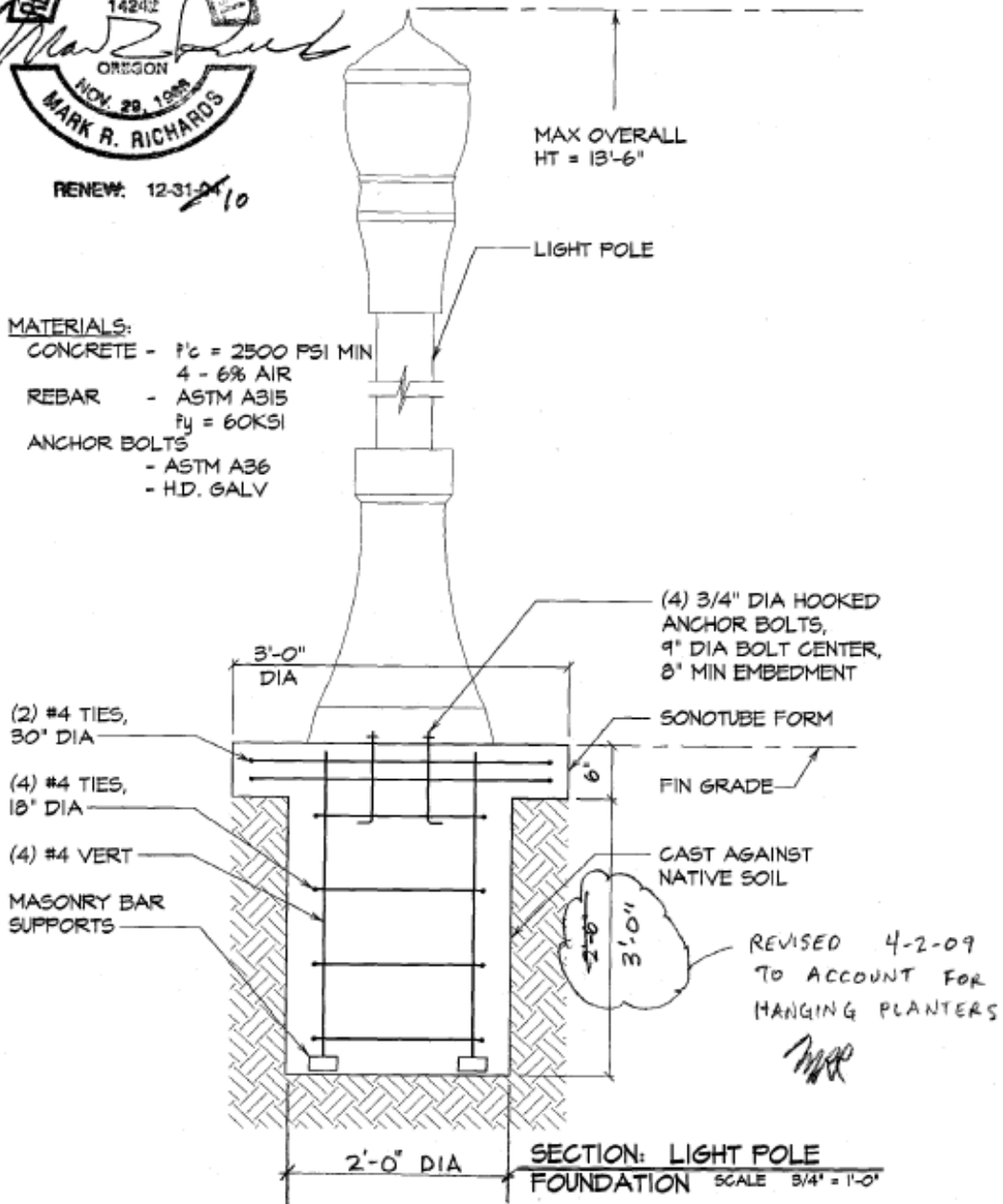

Section 26 50 00 – Lighting continued



PROJECT LIGHT POLE FOUNDATION
 UNIVERSITY OF OREGON
 CALCULATED BY MRR
 DATE 10-21-2008
 Revised 4-2-09

LIGHT POLE FOUNDATION

POLE HT 12'-0"
 POLE DIA 6"
 GLOBE DIA 1'-6"
 POLE WT. 100 LBS
 GLOBE WT 100 LBS

WIND OVERTURNING AT 20 PSF WIND

$$M = .02 (.5 \times 12^2 / 2 + .75 \times 2 \times \pi \times 12.75) = 1.17 \text{ FT-K}$$

$$V = .16 \text{ K}$$

SEISMIC OVERTURNING AT V = .5g

$$M = .5 (.1 \times 6 + .1 \times 12.75) = .94 \text{ FT-K}$$

$$V = .1 \text{ K}$$

WIND GOVERNS

POLE FOUNDATION, NONCONSTRAINED

2'-0" DIA
 3'-0" DEEP
 CLASS 5 SOIL 100 PCF LATERAL BEARING X 1.33 X 2 = 266 PCF

$$A = 2.34 \times .16 / .266 \times 2 = .851$$

$$d = .5 \times (.851) [1 + (1 + 4.36 \times 7.3 / .851)^2] = 2.74' < 3.0 \text{ FT} \therefore \text{OK}$$

ANCHOR BOLTS

3/4" DIA
 9" DIA BOLT CENTER
 $T = M/D = 1.17 \times 12 / 9 = 1.56 \text{ K}$
 3/4" BOLT O.K. FOR 2.7K W/ 5" EMB



4-2-09
 ADDED FLOWERS

(2) FLOWER BASKETS @ 9'-0" HT
 WT = 35 LBS EA
 A = 2.5 SF

$$M_{wind} = 1.17 + 2 \times 2.5 \times 9' \times .02 = 2.07 \text{ K}$$

$$V_{wind} = .16 + 2 \times 2.5 \times .02 = .26 \text{ K}$$

$$M_{seismic} = .94 + 2 \times .035 \times 5 \times 9 = 1.26 \text{ K}$$

$$V_{seis} = .1 + 2 \times .035 \times 5 = .135$$

$$A = 2.34 \times .26 / .266 \times 2 = 1.14$$

$$d = .5 \times (1.14) [1 + (1 + (4.36 \times 7.96 / 1.14)^2)] = 3.30'$$

USE 3'-6" DEPTH

End of Section

END OF DIVISION 26

PAINT SPECIFICATION

ALL CAST IRON AND STEEL LIGHT POLE PARTS ARE TO BE FACTORY POWDER COATED "U OF O GREEN RAL #6005".

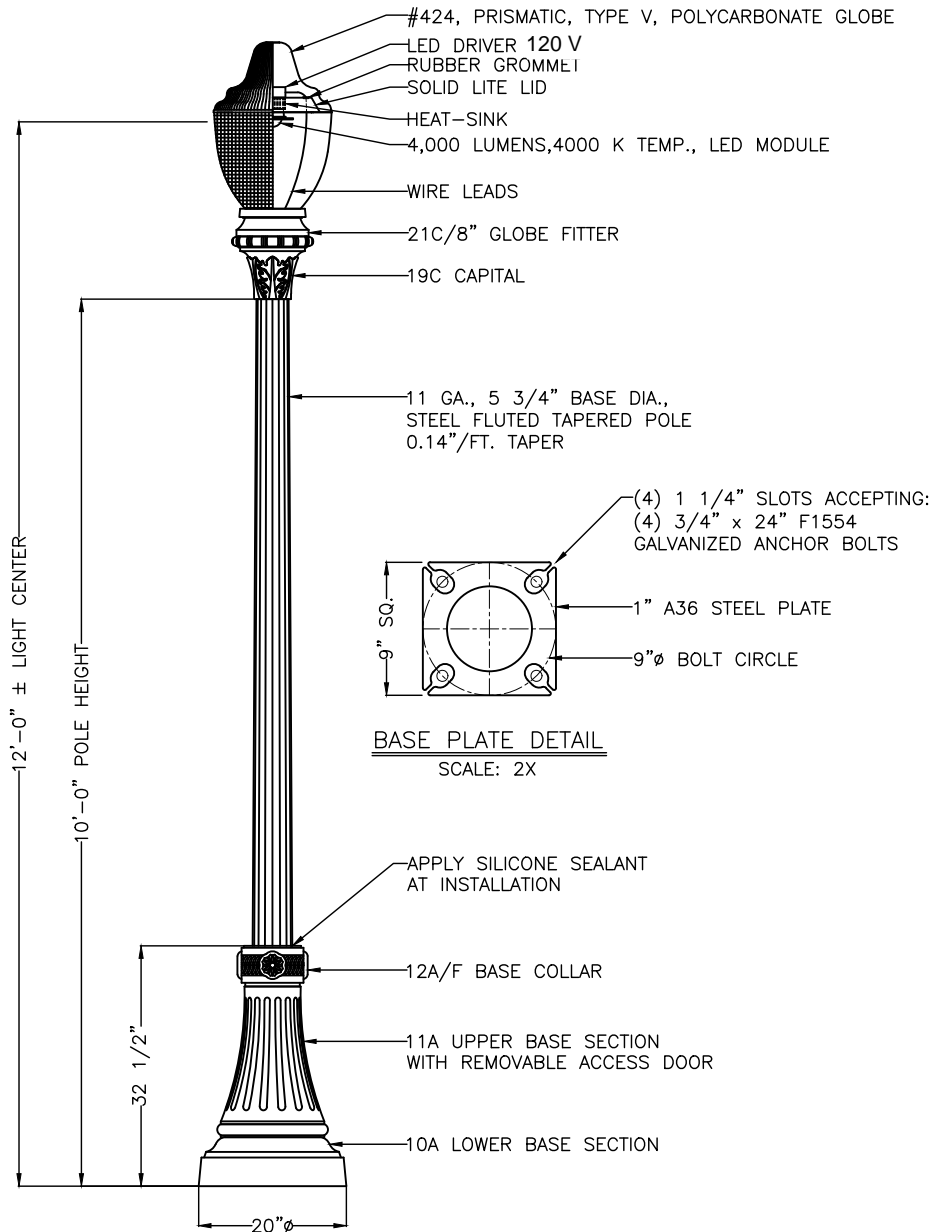

BASE PLATE DETAIL
SCALE: 2X

VI-A-1-F/10'

PROJECT TITLE:	UNIVERSITY OF OREGON EUGENE, OREGON	
DISTRIBUTOR:		
CONTRACTOR:		
REPRESENTATIVE:		
	SPECIFIED BY:	
	SCALE: FULL	DATE: 1/28/19
	JOB NO.:	CAD FILE:UOFO-STD-LED
<small>29579 AWBREY LANE EUGENE, OREGON 97402 PHONE (541) 688-7741 FAX (541) 461-0951</small>		