

**SECTION 32 10 00: Exterior Improvements**

Document revision history: 08/2019 – Original Publication

Date	Section	Description of Change

**PART 1 – GENERAL**

**1.1 Summary**

- a. Not applicable.

**1.2 Submittals**

- a. Product data.

**1.3 Qualifications**

- b. Not applicable.

**PART 2 – PRODUCTS**

**1.1 Materials**

- a. All non-approved exterior furnishings proposed for publicly viewed areas on campus require CPC and/or Campus Planning review and approval.
- b. Outdoor furnishings within building courtyards or private outdoor spaces, not seen by the public, are at the discretion of the building occupants and departments. Notification to Campus Planning is recommended prior to purchase.

**1.2 Site Furnishings**

- a. Removable Bollards, OFCI: VISCO #VI-BO-14-30-RB, aluminum construction, powder-coated UO Green.

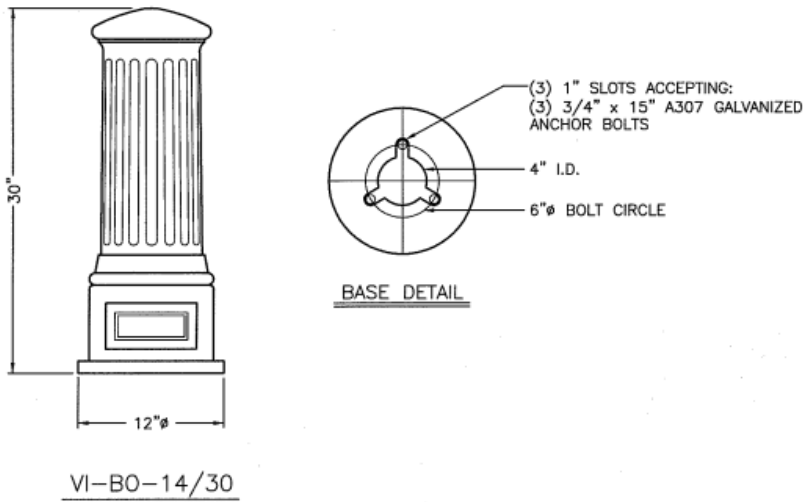

- b. Permanent Bollards, OFCI: VISCO #VI-BO-14, powder-coated UO Green.

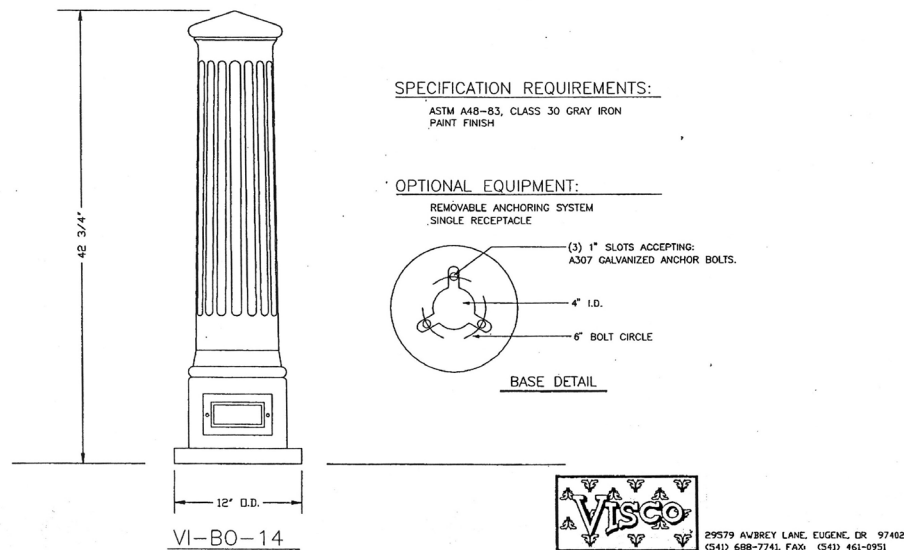

- c. Exterior Benches, OFCI: Parkside, Model #2604 by Gardenside, LTD.
- General Data:
    - i. Where possible, incorporate exterior seating into site walls and ledges.
    - ii. Bolt down benches with bracket and anchors provided by Owner.
    - iii. 5 foot length is preferred. 6 foot length to be approved by Owner.
- d. Trash Cans, OFCI: Anova #L2900 Metrix 40 gallon receptacle with single side door; Powder coat UO Green.
- e. Bike Parking Racks, OFCI: Round Hoop Style Rail Mount Model by Radius Pipe Bending, or equal.
- Contact Campus Planning for bike parking requirements.
  - Campus Planning and Facility Services oversee the placement of bicycle parking and the development of circulation systems.
  - All bike parking must be identified on Site Plans and locations reviewed by Campus Planning.
  - Hoop style racks on metal rails are preferred and are to be powder coated UO Green.
  - Product Data:
    - i. Hoop Rack Material: 1-7/8" OD ASTM A53 Schedule 40 Steel Pipe.
    - ii. Height: 36 inches
    - iii. Hoop Width: 18 inches
    - iv. Spacing: 36 inches between hoops is preferred. Spacing can be reduced to 30 inches between hoops with Owner approval.
    - v. Rail Mount Material: 1" x 2" x 1/8" bar channel with 2 - 1/2" holes for anchoring near each hoop. Bike racks with 2 hoops to have 4 holes, 3 hoops to have 6 holes, etc. Coordinate type of anchor with Owner.



- For individually mounted hoop racks install with a flange mount pad with the following characteristics: 6” round, ¼” steel plate with (2) ½” holes for anchoring.
- For other styles of bike racks (rib, wave, hair-pin, diagonal hoop, etc.) Campus Planning approval is required.
- Where vertical racks are used follow the manufacturer’s recommended spacing and mounting requirements.
- Consider the layout and design of bike parking to accommodate a wide range of styles and types of bikes. Coordinate with Campus Planning.

f. Bicycle lockers, CFCI:

- In general, where there are existing bike lockers match the color of existing lockers. Where there are no other lockers in the area lockers to be UO Green. Confirm color with Campus Planning.
- Minimum aisle dimension is 5 feet.
- Handle Style: T-handle with lock.
- Double bike lockers.
- Approved products:
  - i. Cycle-Safe, ProPark Standard Model (Mo6): (<https://cyclesafe.com/bike-parking/bike-lockers/propark-standard-model/>), or approved equal.
  - ii. Huntco, BV-2 Double Bike Locker: (<https://huntco.com/double-bike-locker>)

#### 1.4 Skate Deterrents

- a. All seat and retaining walls less than 5 feet in height must utilize anti-skating strategies. Integrate skate deterrents or interruption strategies into the design of the concrete. Skate deterrents or strategies shall not be secured in mortar joints.
- b. Unless otherwise specified. Typical OFOI skate deterrents:

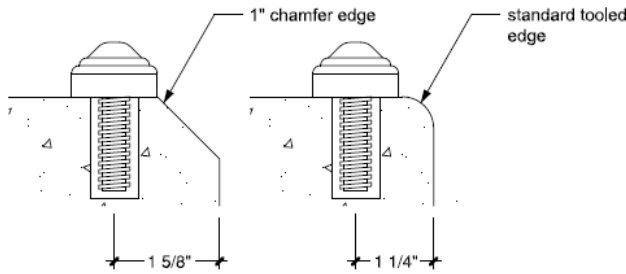

**NOTES:**

- Skateboard bumps provided by University (hot dip galvanized or standard green powder coated finish).
- 1 ¼" minimum on center set back from edge of wall.
- 2' to 3' spacing on center (depending upon wall material and jointing).
- Bumps to be anchored in a 5/8" hole by epoxy cement.

**ANTI-SKATEBOARD BUMP**  
**Typical Installation**



**PART 3 – EXECUTION**

**1.5 Site Paving**

- a. Vehicle loaded access shall be provided at building perimeters for the purpose of maintenance activities.
- b. All ADA accessible parking spaces and aisles must be constructed in concrete.

**1.6 Sidewalks**

- b. If utility vaults, metal covers, etc. are located in sidewalks the surface is to be textured to reduce slip hazards.
- c. All ADA accessible routes must be constructed in concrete.
- d. Water vaults are not to be located in sidewalks.
- e. Standard sidewalk detail: Standard sidewalks designed to support pedestrian traffic only will have a minimum of 4 inches of 4000psi concrete with a 6 inch minimum of base rock.

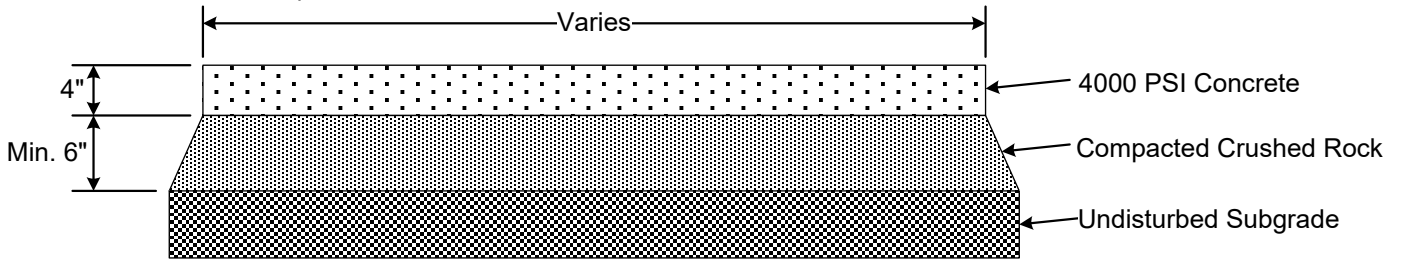

**Standard Walk**

No Scale

- f. Vehicle loaded sidewalk detail: Sidewalks designed to support vehicle weight will have thickened edges and rebar to support vehicle weight; minimum of 6 inches of 4000psi concrete with a 4 inch minimum of base rock at the outside thickened edge.

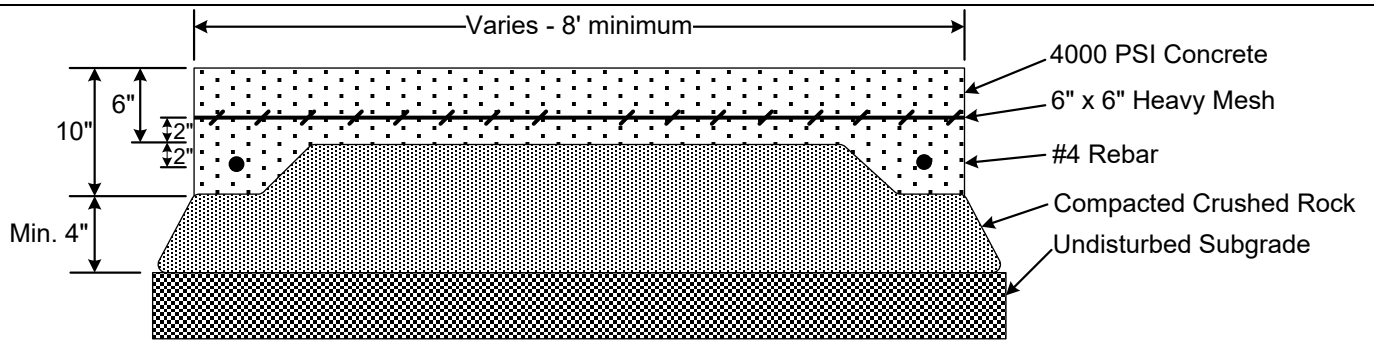

**Maintenance Vehicle Access Sidewalk**

No Scale

**End of Section**

**SECTION 32 80 00: Irrigation**

Document revision history: 2/2022 Original Publication

Date	Section	Description of Change
3-16-23	3.5.g	Added image detail for zone valve assembly
5-4-26	Throughout 32 80 00.	Switching Toro brand controllers to Hunter brand controllers. Controllers will be Ethernet/internet enabled. Hunter brand controllers will need hunter decoders on 2-wire systems

**PART 1 – GENERAL****1.1 Summary**

- a. Prior to design, the Owner’s Representative (OR) will coordinate a meeting with the design team and Irrigation Coordinator.
- b. New irrigation systems should be a 2-wire, fully automatic irrigation system connected to the university’s Ethernet, Hunter’s Centralis central control irrigation system.
- c. Where projects impact existing, multi-strand irrigation coordinate with Owner’s Representative whether a conversion to a two-wire system is necessary.
- d. All projects that impact campus landscapes and irrigation should ensure a fully operational, complete irrigation system upon project completion.
- e. Prior to construction, determine impacts to irrigation systems and establish temporary irrigation as needed. It is typical for existing irrigation to extend beyond project limits and it critical existing landscapes are not negatively impacted due to interruptions of irrigation.

**1.2 Submittals**

- a. Product data
- b. Irrigation As-built Drawing will be submitted to Owner’s Representative to coordinate review with the Irrigation Coordinator.

**1.3 Qualifications**

- a. During the plan review process, the OR will coordinate the approval, and sign off, from the Irrigation Coordinator.

**PART 2 – PRODUCTS****2.1 Pipe, Fittings, Sleeves**

- a. PVC Type I, NSF approved as per ASTM-Do1784, D-1785, D-2242 and Product Standard 21/70, 22/70.
- b. All lateral lines are to be schedule 40 with solvent-weld connection fittings.
- c. PVC fittings to be schedule 40, solvent-weld type.
- d. All mainline pipes to be schedule 40.
- e. No galvanized pipe or fittings may be used.
- f. Sleeves to be schedule 40 PVC.

**2.2 Manual Control Gate Valves**

- a. Use USA manufactured valves, resilient seat gate valves.
- b. 125 PSI cold-water-rated, construction to be brass or bronze on 2-inches and under sizes.
- c. All gate valves to have wheel handled operations.

**2.3 Electric Remote Control Valves**

- a. Rainbird PEB Series.
- b. Attach cow tags with number station valve.
- c. Install unions on both sides of control valve.
- d. Add wireless valve link if plan calls for it.

LEGEND

- |  |  |
|--|--|
| <ul style="list-style-type: none"> <li>① HUNTER WIRELESS VALVE LINK (WVL) PER PLAN</li> <li>② IRRIGATION VALVE BOX PER PLAN:<br/>HEAT STAMP LID WITH 'RCV' IN 2" LETTERS,<br/>DRILL 1.5" [38MM] HOLE</li> <li>③ 18"-24" [50 CM] COILED WIRE TO DC LATCHING<br/>SOLENOID WITH WATERPROOF CONNECTORS</li> <li>④ HUNTER REMOTE CONTROL VALVE (ICV)<br/>WITH DC LATCHING SOLENOID</li> <li>⑤ FINISHED GRADE</li> </ul> | <ul style="list-style-type: none"> <li>⑥ SCH. 80 CLOSE NIPPLE EACH SIZE:<br/>MATCH SIZE TO VALVE</li> <li>⑦ PVC SLIP X FPT ADAPTOR EACH SIDE</li> <li>⑧ BRICK SUPPORTS (4)</li> <li>⑨ FILTER FABRIC: WRAP TWICE AROUND BRICK<br/>SUPPORTS</li> <li>⑩ GRAVEL BASE: DEPTH AS SPECIFIED</li> <li>⑪ IRRIGATION LATERAL</li> <li>⑫ MAINLINE AND FITTINGS</li> </ul> |
|--|--|

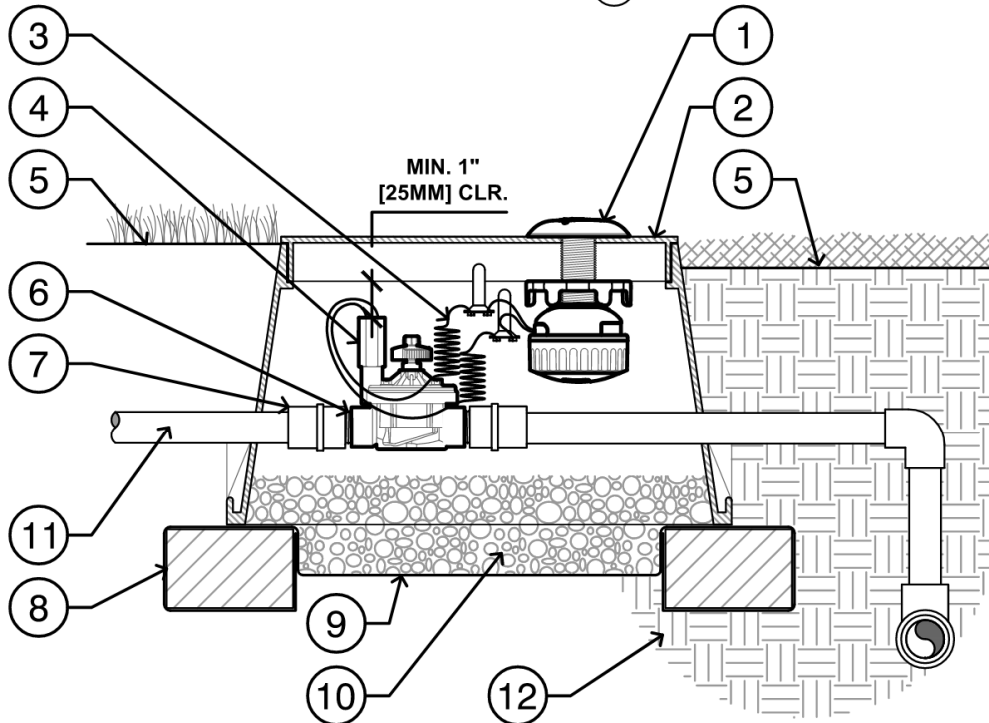

**WIRELESS VALVE LINK WITH ICV VALVE**

N.T.S.

C-WVL-02 | www.hunterindustries.com | **Hunter**

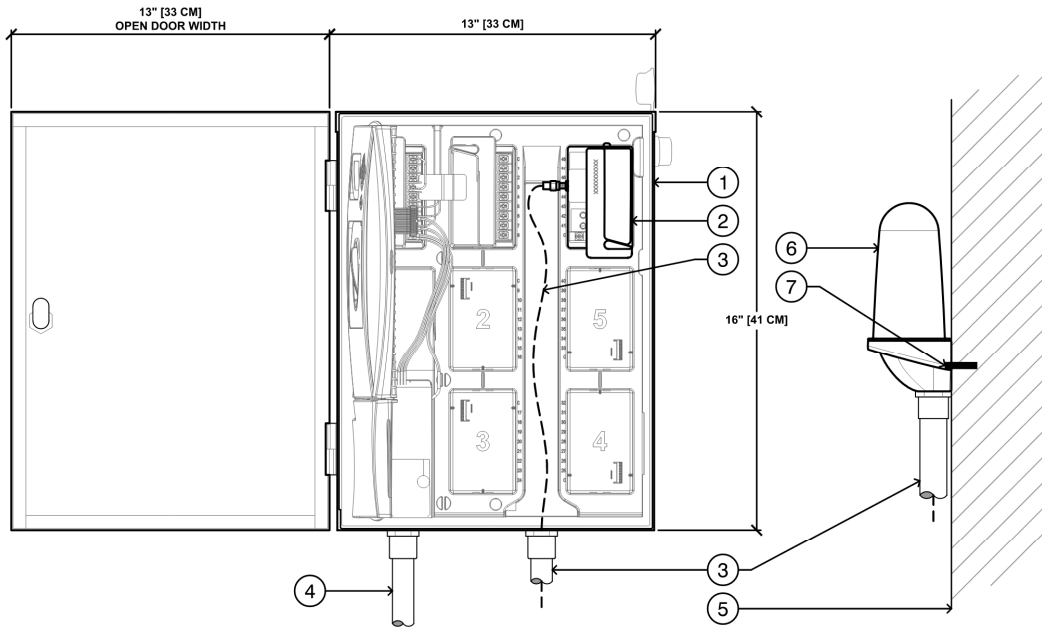

**LEGEND**

- ① HUNTER IRRIGATION CONTROLLER (I2C-800-M OR HCC-800-M) PER PLAN
- ② HUNTER WIRELESS VALVE OUTPUT MODULE (WVOM)
- ③ ANTENNA CABLE IN CONDUIT: MAXIMUM LENGTH 9' [3M]
- ④ ELECTRICAL SUPPLY CONDUIT: CONNECT TO POWER SOURCE, J-BOX INSIDE CONTROLLER
- ⑤ ADJACENT SURFACE TO MOUNT PER PLAN
- ⑥ HUNTER WVOM ANTENNA EXTENSION KIT (ANTEXTKIT)
- ⑦ FASTENERS OR CONCRETE ANCHORS BY OTHERS (2)

**NOTES**

- 1. WIRELESS VALVE OUTPUT MODULE ANTENNA EXTENSION KIT REQUIRED FOR METAL ENCLOSURE.
- 2. CONTROLLER ACCEPTS 120 VOLTS A.C. OR 230 VOLTS A.C. (INTERNATIONAL MODEL).
- 3. MOUNT CONTROLLER LCD SCREEN AT EYE LEVEL, CONTROLLER SHALL BE HARD-WIRED TO GROUNDED 110 VAC POWER SOURCE.
- 4. REFER TO THE HUNTER INSTALLATION GUIDE FOR FURTHER INSTRUCTIONS.

**00 IRRIGATION CONTROLLER: WIRELESS VALVE OUTPUT MODULE, METAL ENCLOSURE**

N.T.S.

C-WVL-WVOM-02 | www.hunterindustries.com |

**2.4 Backflow Preventer**

- a. Conbraco top entry double check valves.
- b. Models must be designated for operation at an elevation with respect to the system.

**2.5 PVC Primer**

- a. Oatey Lo-V.O.C. purple primer #31903

**2.6 Glue**

- a. IPS Corporation Weld-On 705 PVC or 721 PVC.
- b. Ensure that manufacturer’s expiration date is not exceeded.

**2.7 Quick Coupling Valves**

- a. Rain Bird 44RC

**2.8 Flow Sensors**

- a. Ultrasonic Flow Sensor Electronics Insert, For Schedule 80 PVC Tee
- b. Schedule 80 PVC Socket Tee for FLOMEC Sonic Series Flow sensor.

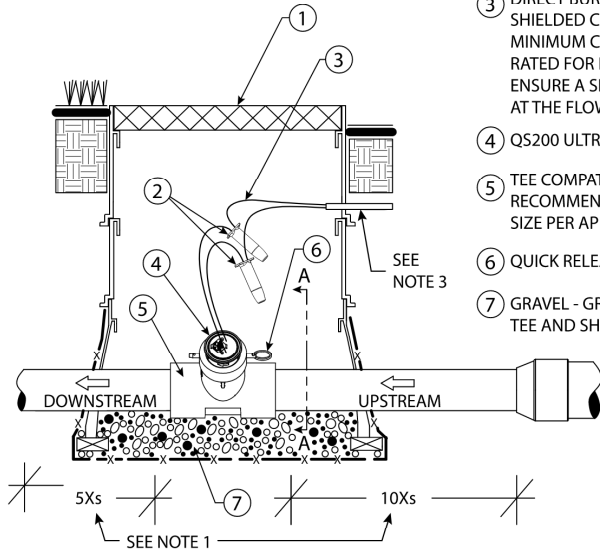

- ① PLASTIC VALVE BOX TO PROVIDE ACCESS.
- ② 3M DBR/Y-6 SPLICE KIT OR EQUIVALENT DIRECT BURIAL SPLICE KIT
- ③ DIRECT BURIAL 1 PAIR, TWISTED SHIELDED CABLE. RECOMMENDED MINIMUM CONDUCTER SIZE 18 AWG. RATED FOR DISTANCES UP TO 2,000 FT (610 M). ENSURE A SERVICE LOOP (EXTRA WIRE LENGTH) IS PROVIDED AT THE FLOW SENSOR IN CASE MAINTENANCE IS NEEDED
- ④ QS200 ULTRASONIC FLOW SENSOR
- ⑤ TEE COMPATIBLE WITH QS200 (FLOMEC QS200 TEE RECOMMENDED FOR BEST RESULTS). SELECT TEE SIZE PER APPLICATION FLOW RATES REQ'D (SEE DATA SHEET)
- ⑥ QUICK RELEASE PIN
- ⑦ GRAVEL - GRAVEL SHALL BE PLACED AT BOTTOM OF QS200 TEE AND SHALL BE A MINIMUM OF 10-INCH THICK (10-INCH DEEP)

**NOTE 1:**  
PREFERRED 10X PIPE DIAMETER UPSTREAM AND 5X PIPE DIAMETER DOWNSTREAM OF STRAIGHT PIPE TO ACHIEVE BEST ACCURACY

**NOTE 2:**  
IF SPACE ALLOWS, INSTALL SENSOR AT A 45 DEGREE ANGLE FROM VERTICAL

**NOTE 3:**  
BURIED CABLE ENROUTE TO IRRIGATION CONTROLLER

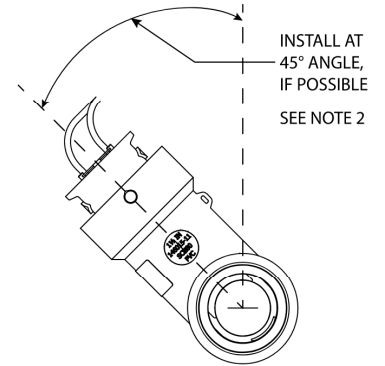

**01** SECTION A-A  
N.T.S.

**00** FLOMEC FLOW SENSOR INSTALLATION  
N.T.S.

IND-1125 REV E

**QS200 FLOW SENSOR INSTALLATION**

Wichita · Sydney



Great Plains Industries, Inc. / 800-835-0113 / greatplainsindustries.com  
Great Plains Industries, Inc. Australia / +61 2 9540 4433 / FLOMEC.com.au

**2.9 Master Valves**

- a. Normally open and same size as mainline.
- b. Mfg: 24V AC, Bermad 410

**2.10 Valve Covers and Boxes**

- a. Double-check valves: Carson 1730-18, T-Lid, green in lawns and black or brown in shrub beds.
- b. Automatic control valves: Carson 1419-12, T-Lid, one valve per box, green in lawns and black or brown in shrub beds.
- c. Quick coupler: Carson 1419-12T-Lid, green in lawns and black or brown in shrub beds.

**2.11 Pipe Joint Tape**

- a. Teflon on all threaded joints.
- b. 4 wraps of Teflon tape.
- c. No pipe dope.

**2.12 Sprinkler Heads**

- a. Spray heads shall be Rainbird 1800 SAM-PRS..
- b. Nozzles shall be MP Rotators, or Rain bird R-Van Rotating, and or Rain bird MPR's spray nozzle
- c. Rotor heads shall be Rainbird 5000+ or 3500+.
- d. No micro-sprays;
- e. Drip irrigation shall use drip emitter tubing and used only where spray heads are not practical.
- f. Detail: Stream Rotors.

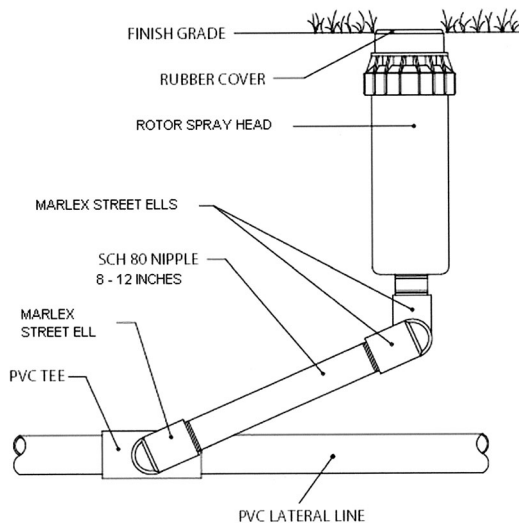

g. f. Swing Joint Pop-up Spray Heads

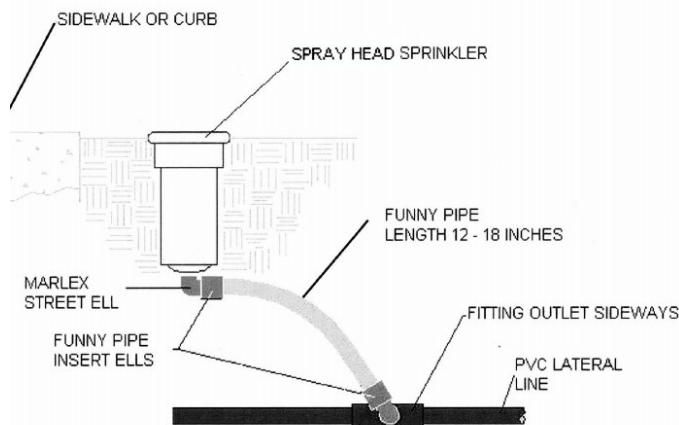

### 2.13 Central Control System

- a. The Water Management System shall be able to link via ethernet and to the Hunter Centralis central control
- b. The System shall include the following general components:
  - Hunter Controller ICC2, ACC2 or the MCC
  - Hunter Communication hardware such as the A2c-LAN or A2C-LTEM
  - Computer to controller communication via Land kit or satellite link kit

**2.14** The irrigation flow sensor shall be a “FLOMEC® QS200 Series FLOMEC® Sonic Series Irrigation Flow Sensor and fitting sized the same as the mainline.

### 2.15 Controller Cabinets

- a. Cabinet shall be the STRONGBOX brand, the SB-24SS or larger, stainless steel wall heavy duty enclosure 24.5”x35.5”x12.21”
- b. Pedestals will be the SB-24SS or larger heavy-duty stainless steel control enclosure measuring 24.5”x35.5”x12.21”
- c. Use A/C decoder unless wire run exceeds 1500ft., then use D/C.
- d. Irrigation controller cabinets and pedestals shall have an UO authorized ethernet port, a 110 power outlet .

- **Example: Exterior Wall Mount Controller**

- i. A Strong box enclosure with an ICC2 inside. Outlet installed in the box. Ethernet installed in the box and 2- 1 inch and a quarter conduit attached.



## 2.16 Conduit and Fittings

- a. Under ground: Plastic, Class III, and Federal Specification W-C-1094.
- b. Above ground: Aluminum, Federal Specification WW-G-540.

## 2.17 Wire

- a. For multi-strand systems: Copper, ASTM B-3, #14 minimum.
- b. Two-wire path wiring per manufacturer's specifications:
  - 14 AWG: 5,000 ft max, 10,000
  - 12 AWG: to 8,000 ft max, 16,000
  - Decoder-to-solenoid wiring: 14 AWG: 150 ft max.
- c. PE-39 cable from controller to flow sensor must be a single, un-spliced length.
- d. Two yellow AWG #12 control wires from controller to normally open master valve must be a single, un-spliced length each.
- e. Tracer wire AWG #14 or along the entire mainline from the controller for each leg of the two wire system.
- f. Do not loop two wire systems
- g. Following Diagram for multibranch 2-wire systems (next page):

**Star Configuration**

For normal installations with 2-wire path runs that are not excessively long, the recommended layout for the 2-wire path is the STAR configuration. This is to facilitate ease of troubleshooting the system should it experience a wire fault or short. The distance of the farthest decoder from controller measured along the 2-wire path is considered the Critical Path of the 2-wire cable for a STAR configuration. The maximum distance for the Critical Path is 1.65 miles for 14 AWG Maxi Cab and 2.63 miles for 12 AWG Maxi Cable. For metric cable the maximum distance for the Critical Path is 3.0 Kilometers for 2.5 mm<sup>2</sup> cable.

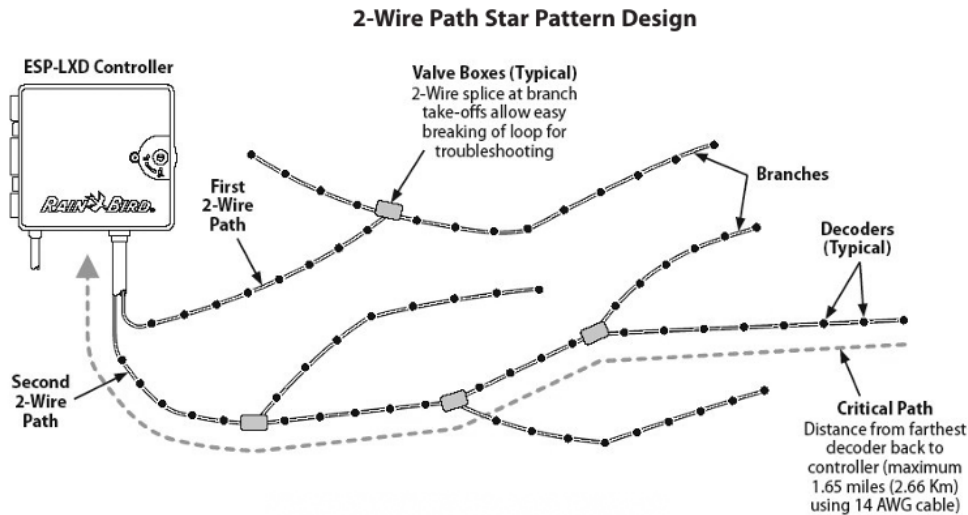
**e. Connectors**

- a. Scotch Lok 3570, 3M DBY

**f. Backfill Materials**

- a. See also Section 32 90 00 Soil Testing.
- b. Planting Areas: Native on-site soil, free of rocks and other deleterious materials. If rock or other deleterious materials are encountered, bed pipe with 4-inches of fill sand on all sides of pipe and/or wire.
- c. Paved Areas: All backfill to be fill sand under paved areas.
- d. Drain and Sump Areas: Pea gravel, 3/4-inch x 1/2-inch washed round rock.

**PART 3 – EXECUTION****3.1 Monuments**

- a. Carefully maintain bench marks, monuments and other reference points.
- b. If disturbed or destroyed, replace as directed.

**3.2 Trenching or Pulling Pipe**

- a. Width of trench to be 1-1/2 times the pipe's outside diameter.
- b. Minimum cover depth to be 18" for main lines and 12" for lateral lines.
- c. Remove any rocks or other material from the bottom of the trench that might damage pipe.

**3.3 Sleeve Installation**

- a. Schedule 40 PVC pipe.
- b. Provide under sidewalks and other locations as selected by/with Owner (in coordination with the Irrigation Coordinator) to install irrigation system and allow future flexibility.
- c. Provide vehicle markers where sleeve ends are concealed.
- d. Extend sleeves a minimum of 1-foot beyond sidewalks on each side.

- e. Run sleeves level and perpendicular to sidewalks and pavement.
- f. Detail:

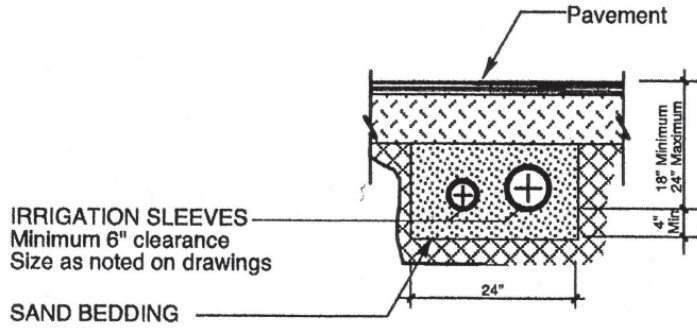

**NOTES**

- Extend sleeves beyond pavement edge or back of curb as noted in specifications. Cover open ends with duct tape.
- Install 2 x 4 red-top, wood location stakes @ both ends of all sleeves and leave 2" above top of curb or pavement.

**3.4 Threaded Plastic Pipe**

- a. Wrap joints with Teflon tape, 4 wraps

**3.5 Valve Covers and Boxes Installation**

- a. Set all valve boxes at grade of lawn or shrub mulch surface.
- b. Ensure excess wire are coiled in box.
- c. 1" minimum clearance from any pipe.
- d. All valve boxes are to be double stacked.
- e. Attach decoder to side of valve box.
- f. Cluster valve boxes together and utilize decoder where practical.
- g. Decoders shall be on the Hunter ICD-decoder series appropriate for the controller model.
- h. Detail:

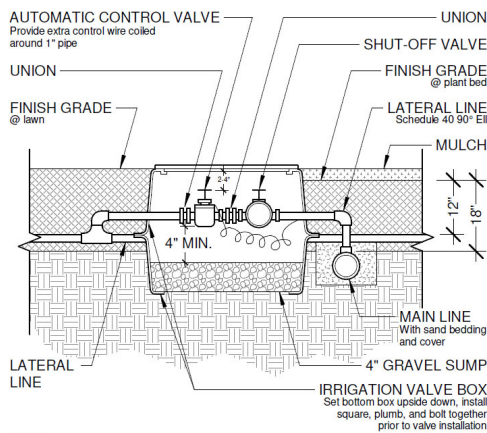

- NOTES:**
- Use Teflon tape on all threaded joints.
  - For two-wire systems mount decoder on side of valve box where applicable.

**ZONE VALVE ASSEMBLY**  
NOT TO SCALE

**3.6 Flushing**

- a. Flush main prior to installing valves.
- b. After piping risers and valves are installed, but prior to installing sprinkler heads, thoroughly flush piping system under full water head. Maintain flushing until all foreign matters are removed from the line.

- c. Cap risers immediately after flushing.

**3.7 Mainline Pressure Test**

- a. Isolate electric valves and test with a pressure pump after installing and before backfilling the mainline.
- b. Maintain 100 psi minimum pressure for at least 24-hours without leaks or pressure loss. Call for Owner’s Representative for inspection at beginning and end of this period. Include a photograph of pressure gauge at the beginning and end of test in the O and M manual.

**3.8 Automatic Control Wire**

- a. At the controller, run low-voltage control wires in metal conduit to 12-inches below grade.
- b. Install wire beneath mainline pipe and coil extra wire at each turn to allow for contraction of wire.
- c. Bundle wire on multi-strand; not necessary on two-wire.
- d. Install wire in continuous runs with no splices.
  - If splices are required confirm with Owner’s Representative, in coordination with Irrigation Coordinator, for approval, make all splices in a valve box and note these on record drawings and provide an extra coil of each wire at each splice to allow for contraction of wire due to temperature or settlement of backfill.
- e. At two-wire systems run spare wire parallel.

**3.9 Quick-Coupling Valve Assembly**

- a. Install plumb in valve box, with top of valve set 3-inches below top of box and grade.
- b. Open crushed rock in valve box to 4-inches below top of valve.
- c. Support quick coupler by attaching an 18-inch #4 rebar with 2 stainless steel clamps on each side.
- d. Install gate valve between quick coupling and valve main line.
- e. Consider location of quick-coupler so that when a system is shut off the quick-coupler is operational without entire system charged.
- f. Detail:

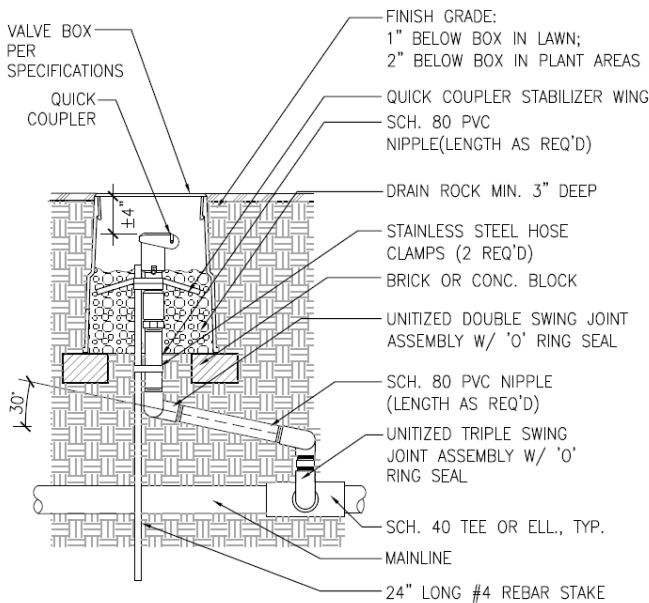

**3.10 Sprinkler Head Installation**

- a. Install all heads plumb or perpendicular to finished grade.
- b. Compact earth under pipe at sprinkler heads to prevent settlement from pulling sprinklers below grade.
- c. Install at center of symbol of drawings, except as follows:

- Do not install any sprinkler body that is next to a sidewalk, curb, header, etc. higher than the top surface of the sidewalk or curb and leave 2 to 3-inches space from sprinkler rim to curb.
  - Part circle sprinkler heads next to buildings, 18 to 24-inches out from the building.
- d. Set head elevations in existing turf, set top of sprinkler flush with top of turf mat or 1/2-inch above earth grade, whichever is highest.
  - e. Consider plant sizes and spacing when designing irrigation systems to ensure irrigation is effective as plants grow.

**3.11 Point of Connection Assembly**

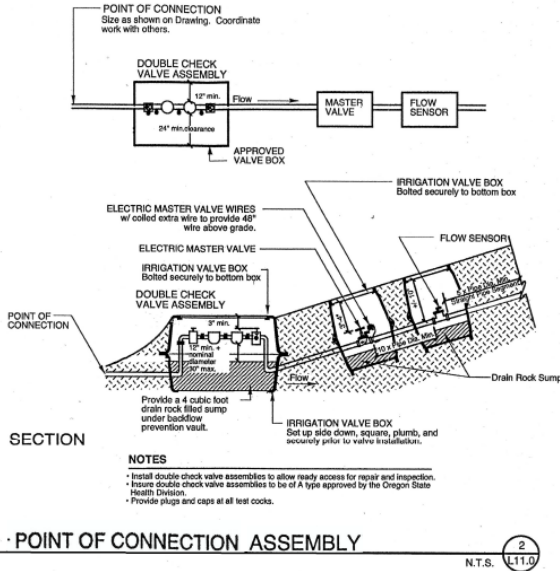

**Note:** Flow sensor must be installed at proper distances from fittings and elbows.

**3.12 Irrigation Record Drawings**

- a. Contractor to provide As-built drawing of irrigation mainline prior to backfilling. As-built drawing to include two dimensions for all mainlines, elbows, tees, or changes of direction.
- b. Final record drawing to include two dimensions locating all valves, wire runs, and final system design showing as built conditions. The drawing shall show the station numbers, station locations, sprinkler head locations, head types, nozzle size, and distance between sprinkler heads.

**3.13 Irrigation Inspection Requirements**

- a. All irrigated landscape areas shall be inspected by the Owner’s Representative, in coordination with the Irrigation Coordinator, before planting to ensure head-to-head coverage and that irrigation system is operating correctly.
- b. Before final completion, review entire system with Owner’s Representative, in coordination with the Irrigation Coordinator, to ensure fully functional and automated.

**SECTION 32 90 00: Planting**

Document revision history: 1/22 Original Publication

Date	Section	Description of Change

**PART 1 – GENERAL**

**1.1 Summary**

**1.2 Submittals**

- a. Products, plants lists and suppliers, contractor information.

**1.3 Qualifications**

- a.

**PART 2 – PRODUCTS**

**2.1 Soil for lawns**

- a. Loam or sandy loam free of noxious weeds, including, but not limited to horse tail; oxalis; morning glory; thistle; etc.

**2.2 Soil for Landscape Areas**

- a. Imported, pre-mixed soil blend intended for shrub and landscape beds composed of loam, compost, and aged bark fines.

**2.3 Seed mix at lawns**

- a. Three-way perennial ryegrass blend suitable for establishing lawns within the Willamette Valley. Specify mix specific to microclimate for sun or shade.

**2.4 Bark Mulch**

- a. Douglas fir bark mulch intended for use in shrub and landscape beds.

**2.5 Imported soil for planting areas shall be Lane Forest frugal mix or approved equal.**

**PART 3 – EXECUTION**

**3.1 Plantings**

- b. Materials likely to require excessive maintenance shall be avoided or judiciously located with Owner’s Representative prior to approval.
- c. 12 inches of soil is required for all lawn/grass areas.
- d. 18 inches of soil is required for all tree, shrub, and planted areas. Excavate to native soil.
- e. Mature width of plant should allow for 2 feet of clearance from buildings.
- f. Mature height and width of plants and trees shall be included with plant list on design and construction documents.
- g. Planting is not allowed within tree drip lines, unless approved by Owners Representative.
- h. Prior to final soil placement:
  - Remove all temporary construction sub-grades.

- Existing subgrade to be scarified prior to final soil placement and planting.
  - No soil tillage under existing tree canopies.
  - Soil and imported soils are to be free of noxious weeds: horse tail; oxalis; morning glory; thistle; etc.
- i. Tree locations:
- See also requirements of the Campus Tree Plan.
  - Trees with fleshy fruits shall not be planted adjacent to paved areas or entries.
  - Consider mature size of tree canopy and its proximity to any building.
  - Ornamental trees shall be planted a minimum of 6 feet from buildings.
- j. Tree locations shall consider maintenance issues. Tree selection:
- Approved street trees are consistent with the City of Eugene street tree list.
- k. Typical tree planting details:

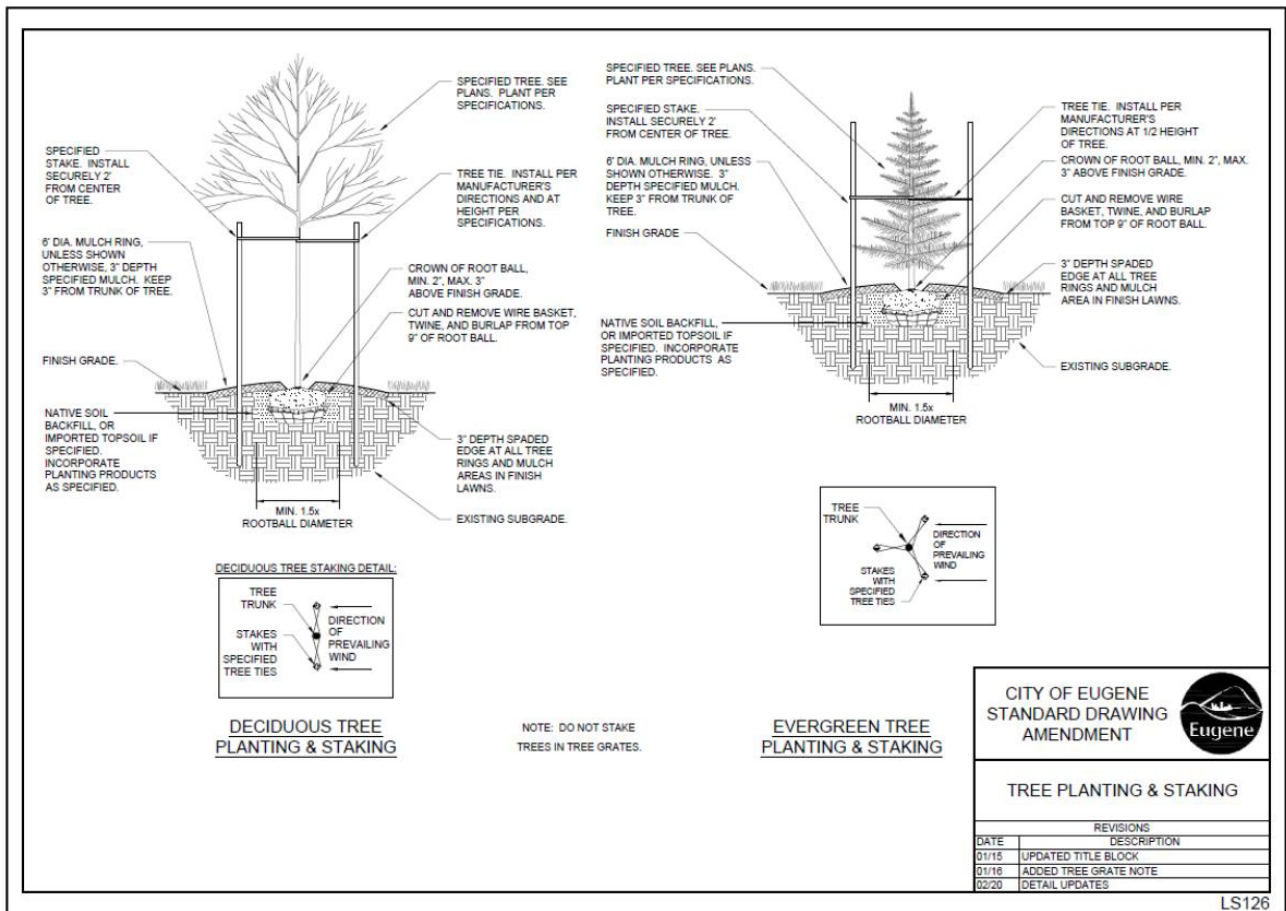

- I. Shrub Planting:
- Remove plant tags, string, and stakes.
  - Do not cover crown of plants with mulch.
- m. Typical shrub planting detail:

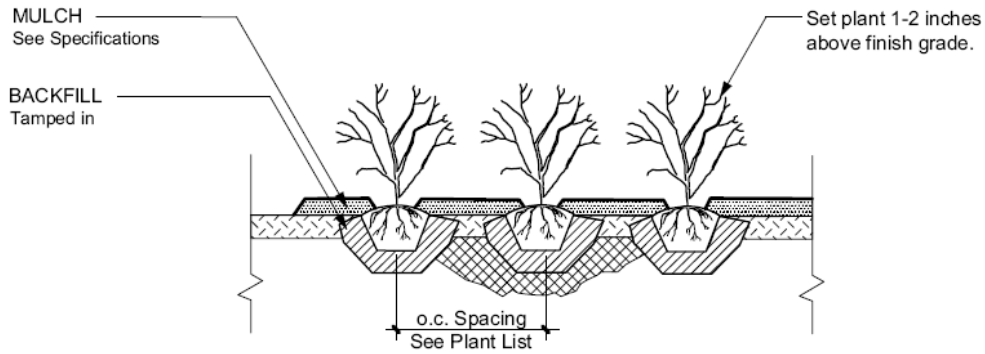

## SHRUB & PERENNIAL

3